

**INTRODUCTION**

The **N2000** Universal Process Controller is a real breakthrough in versatility for holding in one single instrument all the major features required in the vast majority of industrial processes.

With a sophisticated and consistent software and its advanced truly universal circuitry, the **N2000** accepts configuration of both input signal and control output through the front keyboard without any internal hardware change.

Power supply for remote loop powered transmitters is standard and is a must for high-end applications.

From the very simple applications as a temperature controller to the most complex systems of distributed control with PLC's or SCADA networks, the **N2000** is the right answer to your needs for industrial or laboratory automation.

The **N2000S** is specific for applications in controlling servo motorized valves, servo actuators and dampers by means of two time proportional relays.



**FEATURES AND SPECIFICATIONS**

- Accepts thermocouples type J, K, T, N, R, S; Pt100 RTD, linear 4-20 mA, 0-50 mV, 0-5 Vdc.
- Double LED display: red for PV and green for SV.
- Dual SPST 3A/250 Vac relays and dual SPDT 5A/250 Vac relays can be individually programmed for control or alarm.
- Isolated 4-20mA output with 1500-level resolution, maximum 550 ohm load for control or PV/SV retransmission. It can also be configured for digital input or output (10 Vdc/20 mA).
- Sampling rate: 4 measurements per second.
- One digital input for dry contact with 5 programmable functions.
- Remote setpoint input for 4-20 mAdc signal (**N2000**).
- 24 Vdc/30 mA supply output for remote transmitter excitation.
- RS485 comm with Modbus RTU protocol (optional).
- Auto tuning PID control.
- Auto/Manual mode, bumpless transfer.
- Programmable Soft start up to 9999 seconds.
- Ramp and Soak: 7 programs of up to 7 segments each. Can be linked to create longer programs of up to 49 segments.
- Measured value resolution: 12,000 levels.
- Control output update: 250 ms.
- Up to four configurable relays, two timer alarms.
- Alarm functions: LO, HI, differential, differential LO, differential HI, sensor break and event.
- Alarm initial blocking function.
- Power: 85 to 250 Vac, 50/60 Hz; optional 24 Vdc/ac.
- Maximum consumption: 4 VA.
- Front panel: IP65, Polycarbonate UL94 V-2.
- Back panel: IP30, ABS+PC UL94 V-0.
- Circuitry can be removed from the front panel.
- Operating environment: 0 to 55°C, 20 to 90%RH.
- Dimensions: 48 x 96 x 92 mm.
- Panel cutout: 45.5 x 93 mm.
- Weight: 240 g (265 g with options).

For **N2000S** only:

- Potentiometer for actuator position indication.
- Incremental positioning algorithm via 2- relay outputs.

**ELECTRICAL CONNECTIONS**

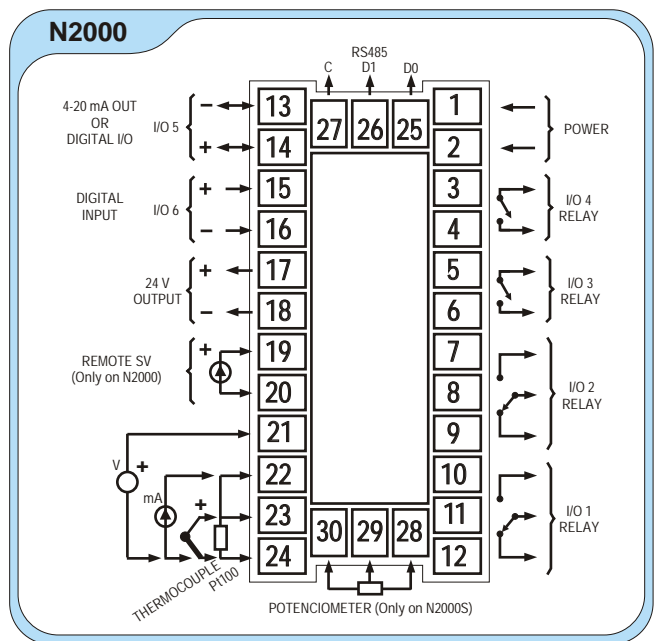

**DIMENSIONS**

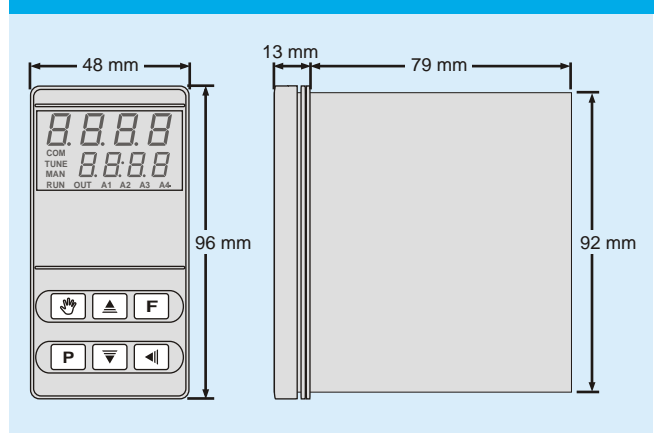

**HOW TO ORDER**

The basic unit includes one universal input, two SPST relays, two SPDT relays, 24Vdc output for powering remote transmitters, one digital input, a 4-20 mA input for remote setpoint and one 4-20 mA output which can also be used as a digital input or output .

In the **N2000S** model the remote setpoint input is replaced by a potentiometer input for indicating actuator positioning.

**Option 1:** RS485 digital communication interface with Modbus RTU protocol.