

# Gruenberg Industrial Ovens

## Truck-In Ovens

Gruenberg manufactures a complete line of truck-in ovens that incorporates various maximum temperatures to accommodate a variety of applications. These ovens include state-of-the-art digital controllers, uniform airflow, convenient safety features, and rugged construction that will provide years of worry-free use. Maximum temperatures include 450° F, 650° F, 800° F, 1000° F, and 1200° F.

#### APPLICATIONS:

- Powder coating
- Drum heating
- Aging
- Core hardening
- Drying
- Preheating
- Curing
- Component testing
- Paint baking
- Plastic curing
- Varnish baking
- Sterilizing
- Rubber and epoxy curing



# Gruenberg

## Truck-in Ovens

### STANDARD FEATURES

#### FRAMEWORK

The interior and exterior walls of all Gruenberg Truck-in Ovens are built around a heavy-duty structural steel frame. The exterior of the oven is 18 gauge cold-rolled steel and is welded to the structural frame. This rugged one-piece, unitized construction ensures durability. The ovens are designed so that all struts are non-continuous from the inner walls to the outer walls. This thermal break minimizes heat transfer to the external oven surface. The exterior surface of the oven is prepared with a primer and painted with blue heat-resistant paint. Higher temperature ovens, those with maximum temperatures of 1000° and 1200°, are finished with a specially formulated high temperature matte black paint.

#### INTERIOR

The interior of the 450°, 650°, and 800° ovens consist of 20 gauge heat-resistant aluminized steel; 1000° ovens have type 304 20 gauge stainless steel; 1200° ovens have type 309 20 gauge stainless steel. Different types of steel are selected for their resistance to heat. The guide tracks for the loading trucks are hot-rolled steel c-channel. For convenience, the ovens have removable duct walls for easy clean-up and maintenance.

#### DOORS

Each door begins with a rigid structural tubular steel frame to ensure the sealing surface stays square as the oven reaches maximum temperature. All doors are attached with industrial hinges, have a two-point, cam-action bar latch, and open a full 90° to allow easy access to the work area. On the 450° and 650° ovens, a silicone rubber gasket is installed around the perimeter of the door opening. 800°, 1000°, and 1200° models are fitted with a P-shaped stainless steel, mesh-covered ceramic core gasket designed to withstand high temperatures without deterioration.

#### Vertical and Horizontal Airflow

A single door is standard on all units with a vertical or horizontal airflow,

except the 96 ft<sup>3</sup> models, which require a double door.

#### Compound Horizontal Airflow

Double doors are standard on all ovens with a compound horizontal airflow.

#### INSULATION

The insulation is chosen for its unique reflective, moisture-proof, non-combustible, and non-settling qualities. It is also asbestos-free and non-hazardous to workers. Each oven is supplied with an optimal amount of insulation to maintain proper heat retention. Between the inner and outer walls of the oven and doors there are four inches of compounded insulation; 1000° units have 5"; 1200° models have 6". Higher temperature models include high temperature block insulation that is installed directly against the oven liner: 800° models have 1", and 1000° and 1200° units have 2", for maximum insulation efficiency. All floors have 3" of insulation.

#### HEATING SYSTEM

Electric heat is supplied by Incoloy-sheathed seamless, tubular heaters that provide excellent energy-efficient output. The heating elements remain at a constant temperature when activated to provide uniform heating throughout the chamber. The heaters are suspended in the plenum adjacent to, but separate from the process chamber so that work in process and operators are protected. Terminal ends are inserted through the insulated walls of the oven and incorporate sufficient dead zones so that heat is not generated beyond the plenum. All heaters are wired with double nut connections.

#### AIRFLOW

##### Horizontal

A circulation blower is located in the top of the oven in a plenum with the heating elements. The blower directs the conditioned air into one side duct wall. The heated air enters the work chamber through the semi-pierced side wall, flows horizontally across the chamber, and exits through the opposite semi-pierced wall. The air is returned back to the plenum for

reconditioning and recirculation. Each semi-pierced wall is manually tuned for maximum temperature uniformity.

#### Vertical with fan on top

A circulation fan is located in a plenum near the top of the oven with the heating elements. The fan directs the conditioned air down through the side duct walls. The heated air enters the workspace near the bottom of the oven and travels vertically up through the chamber to the circulation fan for reconditioning and recirculation.

#### Compound Horizontal

A circulation fan is located in a plenum in the rear of the oven and directs the air into circulation ducts on both sides of the workspace. The air enters the work space through semi-pierced walls over the entire height and depth of the chamber. The air flows horizontally across the product and back to the plenum for reconditioning and recirculation. Each semi-pierced side wall is manually tuned to maximize temperature uniformity throughout the entire chamber. The circulation fan can be operated without heat to purge the chamber for rapid cooling.

#### V-BELT CIRCULATION

All fans and blowers are located entirely within the insulated walls of the oven and are connected to the motor by an extended shaft, pulleys, and a belt. A bearing cooler blower is standard on all units 800°F and above.

#### Vertical and Horizontal Airflow

The electric motor and pulleys are mounted on the top of the oven.

#### Compound Horizontal Airflow

The electric motor and pulleys are mounted in the rear of the oven.

#### INTAKE AND EXHAUST

To regulate airflow, the intake has a slide damper and the exhaust tube has a butterfly damper.

#### AIRFLOW SWITCHES

All standard truck-in ovens include switches to monitor the circulation system. If an airflow interruption is detected, it will shut down power to the heater.

## Truck-in Ovens

### HIGH LIMIT THERMOSTAT

The high limit thermostat has a user-defined preset limit. If the process temperature reaches that preset limit, the high-limit thermostat will de-energize the heating system. To reactivate heating, the high-limit thermostat must be reset manually.

### HEATER LIMIT RELAY

Wired into the control circuit and activated by the high limit thermostat, this relay is in addition to the normal duty relays serving the heater circuits. Should the primary relays fail, this secondary relay is prompted to de-energize the heating system.

### DIGITAL TEMPERATURE CONTROLLER

A solid-state electronic, digital-set and digital read-out temperature controller with thermocouple sensors indicates temperature in degrees F or C with an accuracy of  $\pm 0.25\%$  of scale range.

### CONTROL PANEL

All operating controls for the ovens can be located on the right or left side of the unit in a single panel, thermally insulated from the work chamber. The control placement allows for operating ease and protection from spillage. No wires or connectors are located inside the heating chamber. Circuit wiring is

standard 230V, 3 $\phi$  and includes a step-down transformer for 115V control circuits. Other voltages are optional. Terminals for customers main power supply will be inside the control panel for easy installation.

### TESTING

All Gruenberg ovens are factory tested to maximum temperature before shipment. Arrangements can also be made for testing at your site following installation.

## TYPICAL DESIGN

### COMPOUND HORIZONTAL AIRFLOW

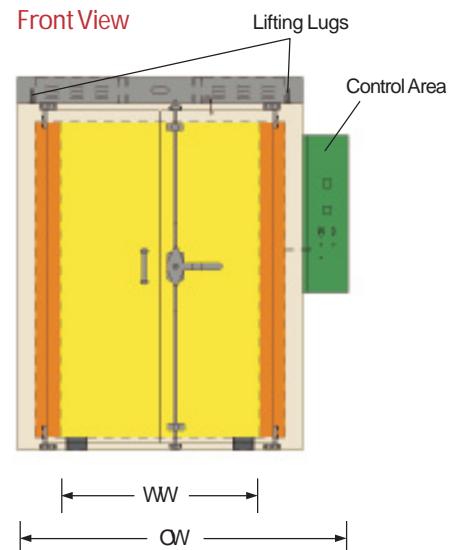
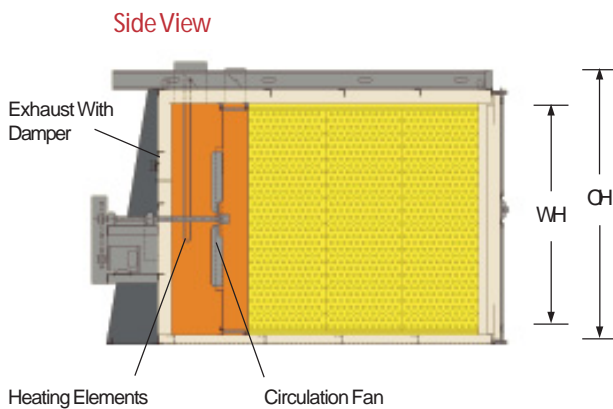
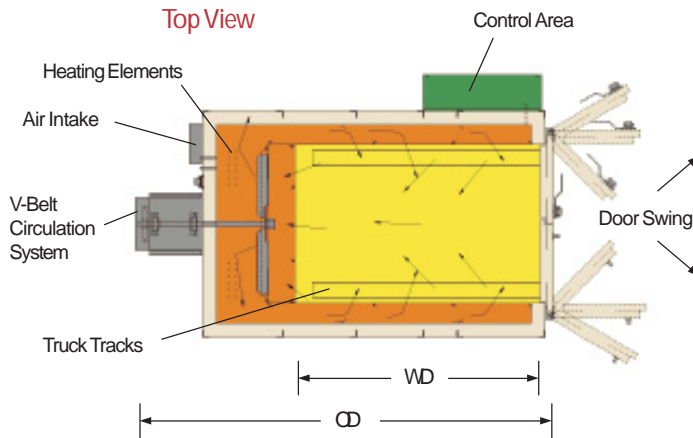

### Dimension Key

WW = Workspace Width	OW = Overall Width
WD = Workspace Depth	OD = Overall Depth
WH = Workspace Height	OH = Overall Height

### Color Key

<span style="background-color: yellow; border: 1px solid black; display: inline-block; width: 15px; height: 10px;"></span> Workspace	<span style="background-color: #d3d3d3; border: 1px solid black; display: inline-block; width: 15px; height: 10px;"></span> Insulated Walls	<span style="background-color: #8b4513; border: 1px solid black; display: inline-block; width: 15px; height: 10px;"></span> Plenum and Duct Walls
--	---	---

# Truck-In Ovens

## TYPICAL DESIGN

Dimension Key	
WW = Workspace Width	OW = Overall Width
WD = Workspace Depth	OD = Overall Depth
WH = Workspace Height	OH = Overall Height

### HORIZONTAL AIRFLOW

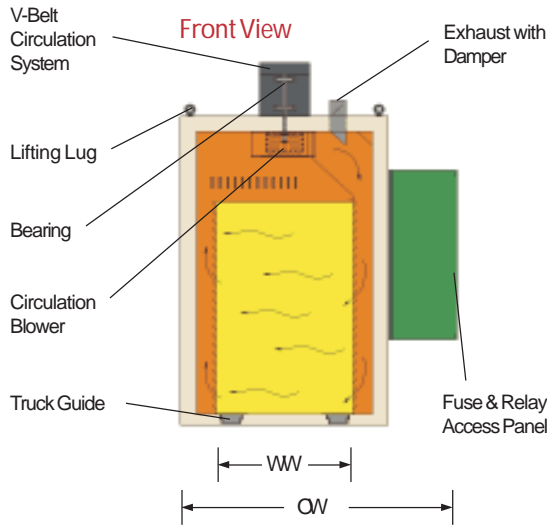
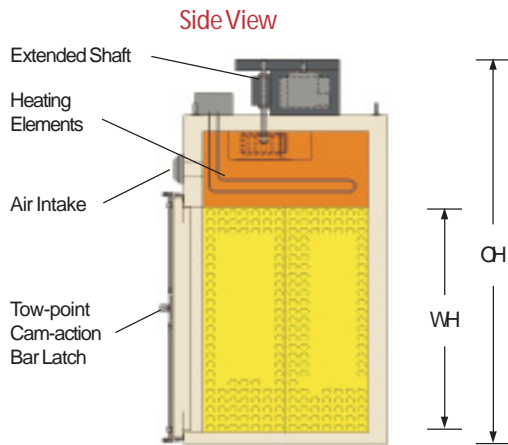
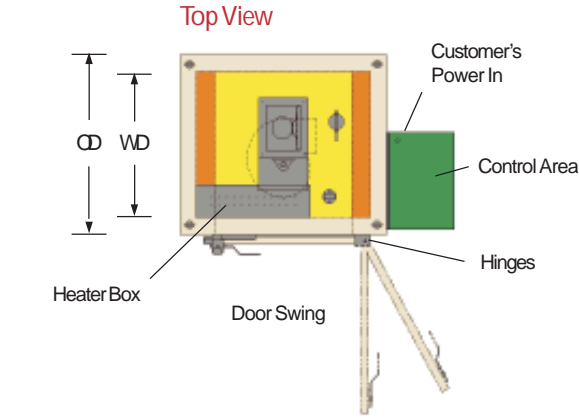

### VERTICAL AIRFLOW

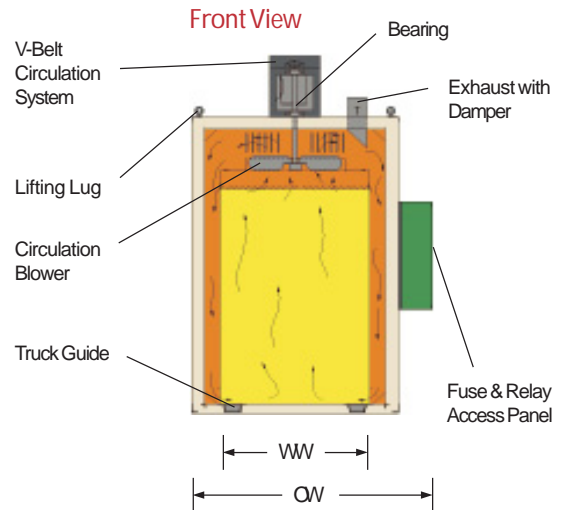
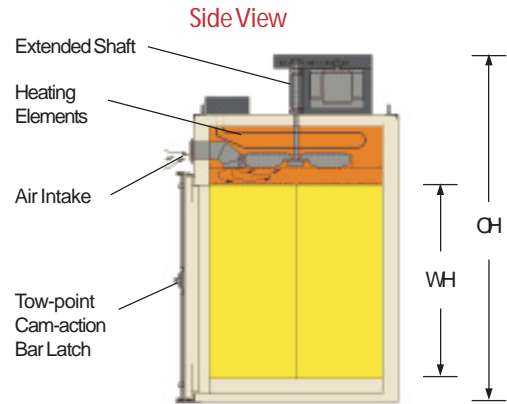
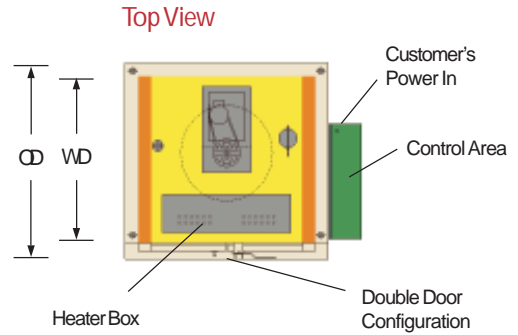

Color Key		
<span style="background-color: yellow; border: 1px solid black; display: inline-block; width: 15px; height: 10px;"></span> Workspace	<span style="background-color: #f0f0f0; border: 1px solid black; display: inline-block; width: 15px; height: 10px;"></span> Insulated Walls	<span style="background-color: #ffa500; border: 1px solid black; display: inline-block; width: 15px; height: 10px;"></span> Plenum and Duct Walls

## 450° F Maximum Temperature

### DIMENSIONS AND SPECIFICATIONS

Capacity ft <sup>3</sup>	Maximum Temperature	Airflow	Interior Dimensions W" x D" x H"	Exterior Dimensions W" x D" x H"	Circulation CFM	Heater Wattage (KW)	Insulation Thickness (inches)	Shipping Weight	Model Number
12	450	Vertical	24 x 24 x 36	54 x 38 x 80	600	9	4 low	900	T45V120
12	450	Horizontal	24 x 24 x 36	54 x 38 x 80	600	9	4 low	900	T45H120
24	450	Vertical	24 x 36 x 48	54 x 50 x 92	1200	12	4 low	1100	T45V240
24	450	Horizontal	24 x 36 x 48	54 x 50 x 92	1200	12	4 low	1100	T45H240
31	450	Vertical	30 x 30 x 60	60 x 44 x 104	1550	15	4 low	1250	T45V310
31	450	Horizontal	30 x 30 x 60	60 x 44 x 104	1550	15	4 low	1250	T45H310
36	450	Vertical	36 x 36 x 48	66 x 50 x 92	1800	18	4 low	1450	T45V360
36	450	Horizontal	36 x 36 x 48	66 x 50 x 92	1800	18	4 low	1450	T45H360
45	450	Vertical	36 x 36 x 60	66 x 50 x 104	2250	24	4 low	1800	T45V450
45	450	Horizontal	36 x 36 x 60	66 x 50 x 104	2250	24	4 low	1800	T45H450
54	450	Vertical	36 x 36 x 72	66 x 50 x 117	2700	24	4 low	2100	T45V540
54	450	Horizontal	36 x 36 x 72	66 x 50 x 117	2700	24	4 low	2100	T45H540
72	450	Vertical	36 x 48 x 72	66 x 62 x 117	3600	27	4 low	2600	T45V720
72	450	Horizontal	36 x 48 x 72	66 x 62 x 117	3600	27	4 low	2600	T45H720
96	450	Vertical	48 x 48 x 72	78 x 62 x 119	4800	30	4 low	2900	T45V960
96	450	Horizontal	48 x 48 x 72	78 x 62 x 119	4800	30	4 low	2900	T45H960
144	450	Comp. Horiz.	48 x 72 x 72	69 x 129 x 88	10500	36	4 low	4680	TK45C144
192	450	Comp. Horiz.	48 x 96 x 72	69 x 153 x 88	13000	45	4 low	5280	TK45C192
204	450	Comp. Horiz.	68 x 72 x 72	91 x 129 x 88	14000	45	4 low	5520	TK45C204
240	450	Comp. Horiz.	48 x 120 x 72	71 x 177 x 88	16000	48	4 low	5400	TK45C240
272	450	Comp. Horiz.	68 x 96 x 72	93 x 153 x 88	18000	54	4 low	6600	TK45C272
340	450	Comp. Horiz.	68 x 120 x 72	93 x 177 x 88	21000	60	4 low	7800	TK45C340
384	450	Comp. Horiz.	96 x 96 x 72	123 x 153 x 88	24500	72	4 low	9216	TK45C384
480	450	Comp. Horiz.	96 x 120 x 72	125 x 177 x 88	29500	90	4 low	11520	TK45C480

## 650° F Maximum Temperature

### DIMENSIONS AND SPECIFICATIONS

Capacity ft <sup>3</sup>	Maximum Temperature	Airflow	Interior Dimensions W" x D" x H"	Exterior Dimensions W" x D" x H"	Circulation CFM	Heater Wattage (KW)	Insulation Thickness (inches)	Shipping Weight	Model Number
12	650	Vertical	24 x 24 x 36	54 x 38 x 80	900	12	4 low	1000	T65V120
12	650	Horizontal	24 x 24 x 36	54 x 38 x 80	900	12	4 low	1000	T65H120
24	650	Vertical	24 x 36 x 48	54 x 50 x 92	1500	18	4 low	1200	T65V240
24	650	Horizontal	24 x 36 x 48	54 x 50 x 92	1500	18	4 low	1200	T65H240
31	650	Vertical	30 x 30 x 60	60 x 44 x 104	1800	24	4 low	1350	T65V310
31	650	Horizontal	30 x 30 x 60	60 x 44 x 104	1800	24	4 low	1350	T65H310
36	650	Vertical	36 x 36 x 48	66 x 50 x 92	2400	24	4 low	1550	T65V360
36	650	Horizontal	36 x 36 x 48	66 x 50 x 92	2400	24	4 low	1550	T65H360
45	650	Vertical	36 x 36 x 60	66 x 50 x 104	3000	27	4 low	1900	T65V450
45	650	Horizontal	36 x 36 x 60	66 x 50 x 104	3000	27	4 low	1900	T65H450
54	650	Vertical	36 x 36 x 72	66 x 50 x 117	3250	30	4 low	2200	T65V540
54	650	Horizontal	36 x 36 x 72	66 x 50 x 117	3250	30	4 low	2200	T65H540
72	650	Vertical	36 x 48 x 72	66 x 62 x 117	4200	36	4 low	2700	T65V720
72	650	Horizontal	36 x 48 x 72	66 x 62 x 117	4200	36	4 low	2700	T65H720
96	650	Vertical	48 x 48 x 72	78 x 62 x 119	5500	36	4 low	3000	T65V960
96	650	Horizontal	48 x 48 x 72	78 x 62 x 119	5500	36	4 low	3000	T65H960
144	650	Comp. Horiz.	48 x 72 x 72	69 x 129 x 88	12500	48	4 low	4680	TK65C144
192	650	Comp. Horiz.	48 x 96 x 72	69 x 153 x 88	15500	54	4 low	5280	TK65C192
204	650	Comp. Horiz.	68 x 72 x 72	91 x 129 x 88	17000	54	4 low	5520	TK65C204
240	650	Comp. Horiz.	48 x 120 x 72	71 x 177 x 88	19500	72	4 low	5400	TK65C240
272	650	Comp. Horiz.	68 x 96 x 72	93 x 153 x 88	22000	72	4 low	6600	TK65C272
340	650	Comp. Horiz.	68 x 120 x 72	93 x 177 x 88	26000	90	4 low	7800	TK65C340
384	650	Comp. Horiz.	96 x 96 x 72	123 x 153 x 88	30000	90	4 low	9216	TK65C384
480	650	Comp. Horiz.	96 x 120 x 72	125 x 177 x 88	35500	108	4 low	11520	TK65C480

## 800° F Maximum Temperature

### DIMENSIONS AND SPECIFICATIONS

Capacity ft <sup>3</sup>	Maximum Temperature	Airflow	Interior Dimensions W" x D" x H"	Exterior Dimensions W" x D" x H"	Circulation CFM	Heater Wattage (KW)	Insulation Thickness (inches)	Shipping Weight	Model Number
12	800	Vertical	24 x 24 x 36	54 x 38 x 80	1000	15	3 low, 1 high	1150	T80V120
12	800	Horizontal	24 x 24 x 36	54 x 38 x 80	1000	15	3 low, 1 high	1150	T80H120
24	800	Vertical	24 x 36 x 48	54 x 50 x 92	1600	24	3 low, 1 high	1350	T80V240
24	800	Horizontal	24 x 36 x 48	54 x 50 x 92	1600	24	3 low, 1 high	1350	T80H240
31	800	Vertical	30 x 30 x 60	60 x 44 x 104	2100	24	3 low, 1 high	1550	T80V310
31	800	Horizontal	30 x 30 x 60	60 x 44 x 104	2100	24	3 low, 1 high	1550	T80H310
36	800	Vertical	36 x 36 x 48	66 x 50 x 92	2500	27	3 low, 1 high	1700	T80V360
36	800	Horizontal	36 x 36 x 48	66 x 50 x 92	2500	27	3 low, 1 high	1700	T80H360
45	800	Vertical	36 x 36 x 60	66 x 50 x 104	3100	30	3 low, 1 high	2050	T80V450
45	800	Horizontal	36 x 36 x 60	66 x 50 x 104	3100	30	3 low, 1 high	2050	T80H450
54	800	Vertical	36 x 36 x 72	66 x 50 x 117	3400	36	3 low, 1 high	2350	T80V540
54	800	Horizontal	36 x 36 x 72	66 x 50 x 117	3400	36	3 low, 1 high	2350	T80H540
72	800	Vertical	36 x 48 x 72	66 x 62 x 117	4300	36	3 low, 1 high	2850	T80V720
72	800	Horizontal	36 x 48 x 72	66 x 62 x 117	4300	36	3 low, 1 high	2850	T80H720
96	800	Vertical	48 x 48 x 72	78 x 62 x 119	5600	45	3 low, 1 high	3150	T80V960
96	800	Horizontal	48 x 48 x 72	78 x 62 x 119	5600	45	3 low, 1 high	3150	T80H960
144	800	Comp. Horiz.	48 x 72 x 72	69 x 129 x 88	14000	60	3 low, 1 high	5160	TK80C144
192	800	Comp. Horiz.	48 x 96 x 72	69 x 153 x 88	18000	72	3 low, 1 high	5760	TK80C192
204	800	Comp. Horiz.	68 x 72 x 72	91 x 129 x 88	195000	90	3 low, 1 high	6000	TK80C204
240	800	Comp. Horiz.	48 x 120 x 72	71 x 177 x 88	22000	90	3 low, 1 high	5880	TK80C240
272	800	Comp. Horiz.	68 x 96 x 72	93 x 153 x 88	25000	108	3 low, 1 high	7080	TK80C272
340	800	Comp. Horiz.	68 x 120 x 72	93 x 177 x 88	25000	108	3 low, 1 high	8280	TK80C340
384	800	Comp. Horiz.	96 x 96 x 72	123 x 153 x 88	34000	126	3 low, 1 high	9720	TK80C384
480	800	Comp. Horiz.	96 x 120 x 72	125 x 177 x 88	40500	144	3 low, 1 high	12000	TK80C480

## 1000° F Maximum Temperature DIMENSIONS AND SPECIFICATIONS

Capacity ft <sup>3</sup>	Maximum Temperature	Airflow	Interior Dimensions W" x D" x H"	Exterior Dimensions W" x D" x H"	Circulation CFM	Heater Wattage (KW)	Insulation Thickness (inches)	Shipping Weight	Model Number
12	1000	Vertical	24 x 24 x 36	56 x 40 x 82	1200	18	3 low, 2 high	1300	T100V120
12	1000	Horizontal	24 x 24 x 36	56 x 40 x 82	1200	18	3 low, 2 high	1300	T100H120
24	1000	Vertical	24 x 36 x 48	56 x 52 x 94	1800	24	3 low, 2 high	1500	T100V240
24	1000	Horizontal	24 x 36 x 48	56 x 52 x 94	1800	24	3 low, 2 high	1500	T100H240
31	1000	Vertical	30 x 30 x 60	62 x 46 x 106	2300	27	3 low, 2 high	1650	T100V310
31	1000	Horizontal	30 x 30 x 60	62 x 46 x 106	2300	27	3 low, 2 high	1650	T100H310
36	1000	Vertical	36 x 36 x 48	68 x 52 x 94	2700	30	3 low, 2 high	1850	T100V360
36	1000	Horizontal	36 x 36 x 48	68 x 52 x 94	2700	30	3 low, 2 high	1850	T100H360
45	1000	Vertical	36 x 36 x 60	68 x 52 x 106	3200	36	3 low, 2 high	2200	T100V450
45	1000	Horizontal	36 x 36 x 60	68 x 52 x 106	3200	36	3 low, 2 high	2200	T100H450
54	1000	Vertical	36 x 36 x 72	68 x 52 x 119	3600	36	3 low, 2 high	2500	T100V540
54	1000	Horizontal	36 x 36 x 72	68 x 52 x 119	3600	36	3 low, 2 high	2500	T100H540
72	1000	Vertical	36 x 48 x 72	68 x 64 x 119	4500	45	3 low, 2 high	3000	T100V720
72	1000	Horizontal	36 x 48 x 72	68 x 64 x 119	4500	45	3 low, 2 high	3000	T100H720
96	1000	Vertical	48 x 48 x 72	80 x 64 x 121	5800	45	3 low, 2 high	3300	T100V960
96	1000	Horizontal	48 x 48 x 72	80 x 64 x 121	5800	45	3 low, 2 high	3300	T100H960
144	1000	Comp. Horiz.	48 x 72 x 72	69 x 131 x 89	16500	72	3 low, 2 high	6000	TK100C144
192	1000	Comp. Horiz.	48 x 96 x 72	69 x 155 x 89	20500	90	3 low, 2 high	6600	TK100C192
204	1000	Comp. Horiz.	68 x 72 x 72	91 x 131 x 89	22500	108	3 low, 2 high	6840	TK100C204
240	1000	Comp. Horiz.	48 x 120 x 72	71 x 179 x 89	25000	108	3 low, 2 high	6720	TK100C240
272	1000	Comp. Horiz.	68 x 96 x 72	93 x 155 x 89	28500	108	3 low, 2 high	7920	TK100C272
340	1000	Comp. Horiz.	68 x 120 x 72	93 x 179 x 89	33500	126	3 low, 2 high	9210	TK100C340
384	1000	Comp. Horiz.	96 x 96 x 72	123 x 155 x 89	39000	144	3 low, 2 high	10560	TK100C384
480	1000	Comp. Horiz.	96 x 120 x 72	125 x 179 x 89	46500	160	3 low, 2 high	12840	TK100C480

## 1200° F Maximum Temperature DIMENSIONS AND SPECIFICATIONS

Capacity ft <sup>3</sup>	Maximum Temperature	Airflow	Interior Dimensions W" x D" x H"	Exterior Dimensions W" x D" x H"	Circulation CFM	Heater Wattage (KW)	Insulation Thickness (inches)	Shipping Weight	Model Number
12	1200	Vertical	24 x 24 x 36	58 x 42 x 84	1500	24	4 low, 2 high	1500	T120V120
12	1200	Horizontal	24 x 24 x 36	58 x 42 x 84	1500	24	4 low, 2 high	1500	T120H120
24	1200	Vertical	24 x 36 x 48	58 x 54 x 96	2100	27	4 low, 2 high	1700	T120V240
24	1200	Horizontal	24 x 36 x 48	58 x 54 x 96	2100	27	4 low, 2 high	1700	T120H240
31	1200	Vertical	30 x 30 x 60	64 x 48 x 108	2600	30	4 low, 2 high	1850	T120V310
31	1200	Horizontal	30 x 30 x 60	64 x 48 x 108	2600	30	4 low, 2 high	1850	T120H310
36	1200	Vertical	36 x 36 x 48	70 x 55 x 96	3000	36	4 low, 2 high	2050	T120V360
36	1200	Horizontal	36 x 36 x 48	70 x 55 x 96	3000	36	4 low, 2 high	2050	T120H360
45	1200	Vertical	36 x 36 x 60	70 x 54 x 108	3600	36	4 low, 2 high	2400	T120V450
45	1200	Horizontal	36 x 36 x 60	70 x 54 x 108	3600	36	4 low, 2 high	2400	T120H450
54	1200	Vertical	36 x 36 x 72	70 x 54 x 121	4000	45	4 low, 2 high	2700	T120V540
54	1200	Horizontal	36 x 36 x 72	70 x 54 x 121	4000	45	4 low, 2 high	2700	T120H540
72	1200	Vertical	36 x 48 x 72	70 x 66 x 121	4800	45	4 low, 2 high	3200	T120V720
72	1200	Horizontal	36 x 48 x 72	70 x 66 x 121	4800	45	4 low, 2 high	3200	T120H720
96	1200	Vertical	48 x 48 x 72	82 x 66 x 123	6200	48	4 low, 2 high	3500	T120V960
96	1200	Horizontal	48 x 48 x 72	82 x 66 x 123	6200	48	4 low, 2 high	3500	T120H960
144	1200	Comp. Horiz.	48 x 72 x 72	73 x 133 x 90	19000	90	4 low, 2 high	6960	TK120C144
192	1200	Comp. Horiz.	48 x 96 x 72	73 x 157 x 90	23500	90	4 low, 2 high	7560	TK120C192
204	1200	Comp. Horiz.	68 x 72 x 72	95 x 133 x 90	26000	108	4 low, 2 high	7800	TK120C204
240	1200	Comp. Horiz.	48 x 120 x 72	75 x 181 x 90	29000	108	4 low, 2 high	7680	TK120C240
272	1200	Comp. Horiz.	68 x 96 x 72	97 x 157 x 90	33000	126	4 low, 2 high	8880	TK120C272
340	1200	Comp. Horiz.	68 x 120 x 72	95 x 181 x 90	38500	144	4 low, 2 high	10080	TK120C340
384	1200	Comp. Horiz.	96 x 96 x 72	127 x 157 x 90	45000	144	4 low, 2 high	11520	TK120C384
480	1200	Comp. Horiz.	96 x 120 x 72	127 x 181 x 90	53500	162	4 low, 2 high	13800	TK120C480

## Optional Loading Trucks

### STANDARD FEATURES

Gruenberg offers a line of standard loading trucks designed specifically for each of our standard truck-in ovens.

### CONSTRUCTION

Loading trucks are fabricated of fully-welded structural steel, assuring the processing of full loads in the most efficient manner. All of our trucks roll on six heavy-duty rigid casters. The center pair of casters is installed slightly lower than the end pairs for easy turning and pivoting.

### SHELVES

Three removable angle-framed and reinforced expanded metal shelves are

standard with each truck. Additional shelves may be ordered by truck model number. Custom shelves are also available for extra heavy loading.

### FINISH

High temperature matte black alkyd resin enamel paint.

### TRUCK OPTIONS

Stainless steel trucks, aluminum trucks, custom trucks.

### SHELF OPTIONS

Additional shelves, bar shelves, stainless steel shelves, custom shelves.



### Dimension Key

WW = Workspace Width  
 WD = Workspace Depth  
 WH = Workspace Height  
 OW = Overall Width  
 OD = Overall Depth  
 OH = Overall Height

### TYPICAL DESIGN

#### Side View

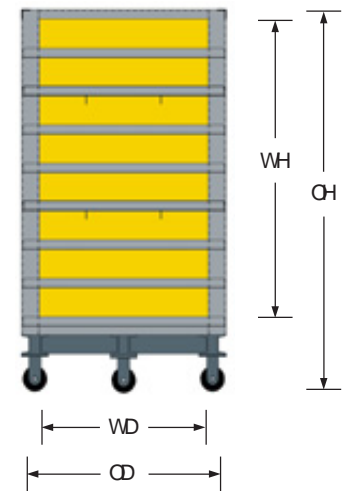

#### Front View



## Optional Loading Trucks

### DIMENSIONS AND SPECIFICATIONS

Model Number	Interior Dimensions W" x D" x H"	Exterior Dimensions W" x D" x H"	Truck Track Spacing	Shelf Spacing	Number of Shelves Supplied	Number of Shelf Guides	Truck Capacities (lbs.)	Expanded Shelf Capacities (lbs.)	Bar Shelf Capacities (lbs.)
T310	25.5 x 28 x 49.5	26 x 28 x 60	22"	6"	3	8	1200	75	150
T360	28.5 x 34 x 37.5	30 x 34 x 60	28"	6"	3	6	1200	100	200
T450	28.5 x 34 x 49.5	32 x 34 x 60	28"	6"	3	8	1600	100	200
T540	28.5 x 34 x 61.5	32 x 34 x 72	28"	6"	3	10	2000	100	200
T720	28.5 x 46 x 61.5	32 x 46 x 72	28"	6"	3	10	2500	125	250
T960	40.5 x 46 x 61.5	44 x 46 x 72	40"	6"	3	10	3000	150	300
TK144	40.5 x 68 x 61.5	44 x 68 x 72	40"	6"	3	10	3500	175	350
TK192	40.5 x 92 x 61.5	92 x 72 x 40	40"	6"	3	10	4000	200	400
TK240	40.5 x 116 x 61.5	44 x 116 x 72	40"	6"	3	10	5000	250	500
TK204	60.5 x 68 x 61.5	64 x 68 x 72	60"	6"	3	10	3500	175	350
TK272	60.5 x 92 x 61.5	64 x 92 x 60	60"	6"	3	10	4000	200	400
TK340	60.5 x 116 x 61.5	64 x 116 x 72	60"	6"	3	10	5000	250	500
TK384	88.5 x 92 x 61.5	92 x 92 x 72	88"	6"	*6	10	8000	200	400
TK480	88.5 x 116 x 61.5	92 x 116 x 72	88"	6"	*6	10	10000	250	500

\*Half shelves

## Oven Options

### CONTINUOUSLY-WELDED LINERS

A continuously-welded liner may be specified to separate the process environment from the insulation and prevent contamination. Continuously-welded liners are commonly used with specific atmospheres such as nitrogen, CO<sub>2</sub>, humidity, or flammables.

### CONTROLLERS:

#### Programmable Temperature Controller: multi-segment

This optional programmable controller with digital set, digital readout, and thermocouple sensor can function as a normal process control or execute any of eight setpoint profiles. Each profile can have six ramp and six soak segments. Any number of profiles can be linked together. Accuracy: ±0.25 of scale range.

#### Other Controllers/Communications

A variety of additional controllers are available to meet your specific needs. Please consult your Gruenberg representative for available options.

### DOOR OPTIONS:

#### Automatic Door Locks

If your product requires uninterrupted processing, these optional automatic door locks will provide additional safety

so that the interior environment will not be accidentally disturbed when the oven is in process.

#### Door Switch

To save energy, especially when you load and unload your oven frequently, the optional door switch turns off the heaters and circulation system when the door opens.

#### Vertical Lift Door

A vertical lift door will allow convenient loading and unloading of oven and provide an economical solution when space constraints limit conventional door swing. Vertical lift doors can be manual, electric motor, or pneumatic. Be sure to verify overhead clearance prior to specifying.

#### Viewing Window

To allow you to view your work in progress, a triple-pane 10" x 10" viewing window is available. Other custom sizes are available upon request.

### EXHAUST BLOWER

Optional exhaust blower removes fumes from the oven chamber at a rate that is set based on the loading characteristics. Note: additional wattage may be needed due to heat loss encountered when using a powered exhaust.

### FORCED COOLING

#### Ambient Air Cooling

Optional ambient air forced cooling provides a quick and economical cool down of the product for rapid unloading. A powered intake blower draws the ambient air into the process chamber during the cooling cycle. During the heat-up and dwell segments, the intake blower remains off and is initiated by the programmable controller after the heat cycle is complete.

#### CO<sub>2</sub> Cooling System

High reliability and rapid cooling are the reasons for liquid CO<sub>2</sub> cooling. The system includes an indicating temperature control, solenoid valve, line strainer, selection switch, pilot lights, and connection base. Stainless steel interiors and continuously-welded liners are recommended with this system.

#### Mechanical Refrigeration Cooling

A mechanical refrigeration package can be supplied for forced-cooling with either a single or cascade system depending upon your requirements.

### FILTRATION OF MAKE-UP AIR: HEPA Filters

Optional HEPA filters can be installed on the air intake. The filters are 99.99%

## Oven Options (CONTINUED)

efficient at particles 0.3 microns or larger and are effective up to 500°F.

### Inlet Air Filters

Either stainless steel or coated aluminum mesh filters keep dirt and dust out of the oven environment.

### LIGHT

Optional interior light is controlled by an exterior switch mounted on the control panel.

### NITROGEN PURGE

The nitrogen purge system creates a nitrogen atmosphere within the work chamber. An automatic high and low flow apparatus includes two inlet valves and a purge timer. The high flow quickly fills the work chamber and the low flow then maintains the resulting nitrogen levels. A continuously welded liner, a water-cooled seal at the circulation fan shaft, and a double door gasket are needed with this system.

### PORTS

Standard port design consists of a 2" sleeved tube through the oven wall. Other sizes are available.

### RECORDERS:

#### Single and Double Pen

Solid-state electronic single-pen recorder is available with either 24-hour or 7-day

recording and has a 10" diameter circular chart and inkless pen. The recorder system comes with a thermocouple temperature sensor accurate to within .5% of range scale.

#### Strip Chart Recorder

You can document your processes with unprecedented precision and accuracy with multiple channels and multiple inputs with this high-speed, microprocessor-based recorder. Three different chart forms can be printed: trend, tabular, or deviation.

#### Other Recorders

A variety of additional recorders are available to meet your specific needs. Please consult your Gruenberg representative for available options.

### SCR POWER CONTROL

This control minimizes temperature swings at the setpoint by proportioning power to the heaters, thus avoiding heat surges and providing excellent uniformity throughout the oven chamber as well as energy savings.

### SHELVING

Additional shelving is available in perforated stainless steel, or solid angle-framed stainless steel. Any custom shelving designs can be accommodated as well.

### SOLVENT VENTING PACKAGE

Almost any oven can be built to accommodate solvent loading. Please see Oven Options Brochure for specifics.

### STAINLESS STEEL INTERIOR

20 gauge, type 304 stainless steel with a 2B finish may be specified for the interior lining, shelves, and shelf brackets. 1000° and 1200° units are supplied with stainless steel interiors (see standard features on page two).

### TIMERS:

#### 24-hour Clock

Warm up your oven before you get to work with a 24-hour clock with automatic on/off settings.

#### Other Timers

Gruenberg offers a wide variety of optional timers, from a simple heat shut-off to a dual timer. Possible options include: timer to shut down heat at end of period but have blowers continue to run; have timer sound alarm at end of period.

#### Purge Timer

The purge timer changes the air within the oven a minimum of four times per minute prior to heating.



*192ft<sup>3</sup>, 1000°F, compound horizontal airflow truck-in oven with optional gas heating package, programmable controller, and recorder.*