

INTRODUCTION

The **RHT-WM-485-LCD** and **RHT-DM-485-LCD** transmitters include high precision and stability sensors for measuring relative humidity and temperature. They are microprocessor based devices and, therefore, allow being entirely configured through an RS485 interface using the Modbus RTU command.

The **DigiConfig** software allows the configuration of all transmitter features as well as its diagnostic procedure.

The **RHT-WM-485-LCD** model is intended for wall mounting while the **RHT-DM-485-LCD** model is equipped with an elongated sensor rod for installation in ducts or through walls.

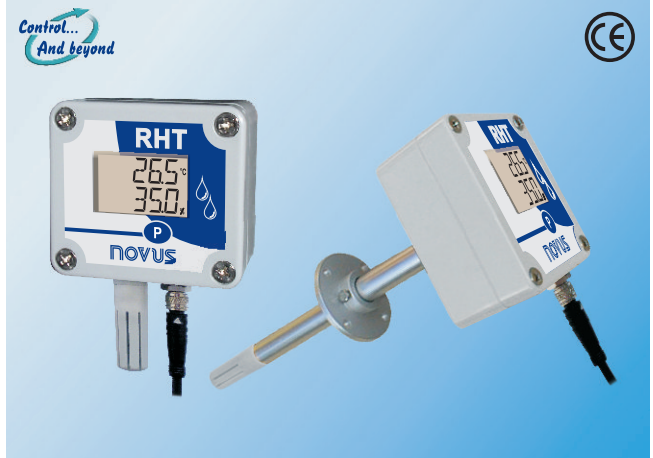

FEATURES

The transmitter can be configured for displaying the values of measured Temperature and Relative Humidity, or the values of measured Temperature and Dew Point, or the values of measured Relative Humidity and Dew Point, or the value of measured Temperature only.

The communication parameters can be easily field-configured. The values for communication address, baud rate and parity can be changed using the frontal button without the need for using the configuration software.

SPECIFICATIONS

- Sensor measuring range:
 - Temperature: -40.0 °C to 100.0 °C (-40.0 °F to 212.0 °F)
 - Relative Humidity (RH): 0.0 to 100.0 % RH
 - Dew Point: -40.0 °C and 100.0 °C (-40.0 °F to 212.0 °F)
- Measuring resolution:
 - Temperature: 0.1 °C, 14 bits (16383 levels)
 - Relative Humidity: 0.1 %, 12 bits (4095 levels)
- Response time:
 - Temperature: up to 30 s in slow air movement
 - Humidity: up to 8 s in smooth air movement (20 to 80%RH)
- Measurement accuracy: refer to figure
- Interval between sampling: 3 seconds
- Power supply: 12 Vdc to 30 Vdc
- Polycarbonate enclosure
- Protection class: Electronic enclosure IP65; Sensor capsule: IP40
- Dimensions: 60 x 70 x 35 mm
- Transmitter operation temperature: from 0 °C to 70 °C
- Electromagnetic compatibility: EM 61326:2000
- Connection cable is included

Measuring Accuracy and Sensor Operational Limits

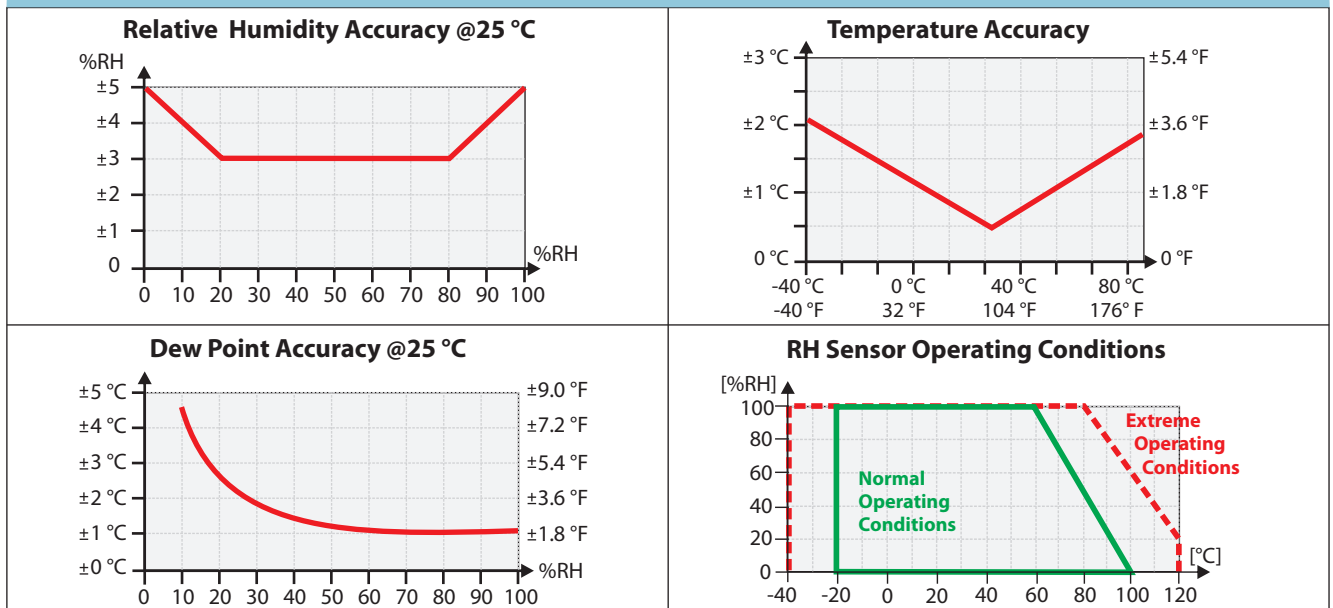

The sensor used in this equipment may be damaged or become out of calibration if it is exposed to chemical agents contaminated atmosphere. Hydrochloric Acid, Nitric Acid, Sulphuric Acid and Ammonia in high concentrations may damage the sensor. Acetone, Ethanol and Propylene Glycol may cause a reversible measurement error.

CONFIGURATION

The **RHT-WM-485-LCD** and **RHT-DM-485-LCD** transmitter are equipped with serial RS485 communication, operating as slave in Modbus RTU protocol. Configuration is entirely performed via serial port.

In order to assure correct configuration of the transmitters, always use the **DigiConfig** software. After being configured, its input and/or output data may be accessed by any other software capable for Modbus RTU communication.

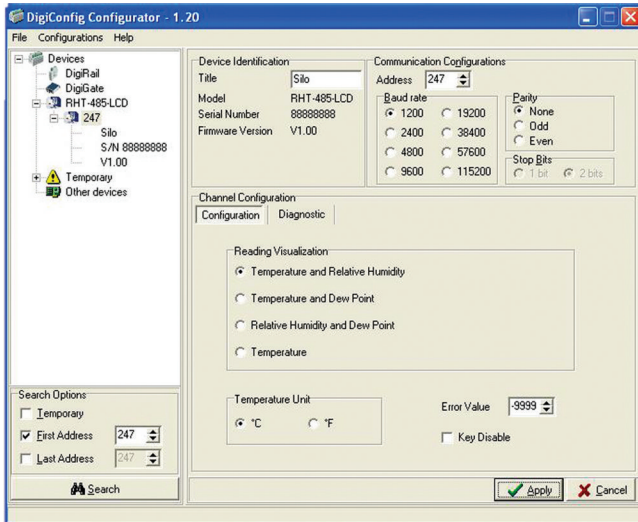

DigiConfig software screen

INSTALLATION

The **RHT-WM-485-LCD** model is designed for wall mounting. Removing the transmitter cover gives the user access to two bores for fixing the base. The transmitter must be fixed with the sensor capsule directed downwards in order to assure the specific accuracy and protection level.

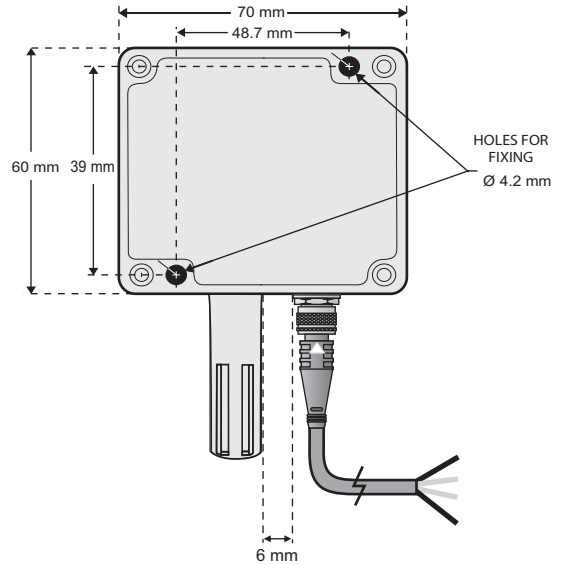

Fixation bores and dimensions of the RHT-WM-485-LCD model

ELECTRICAL CONNECTIONS

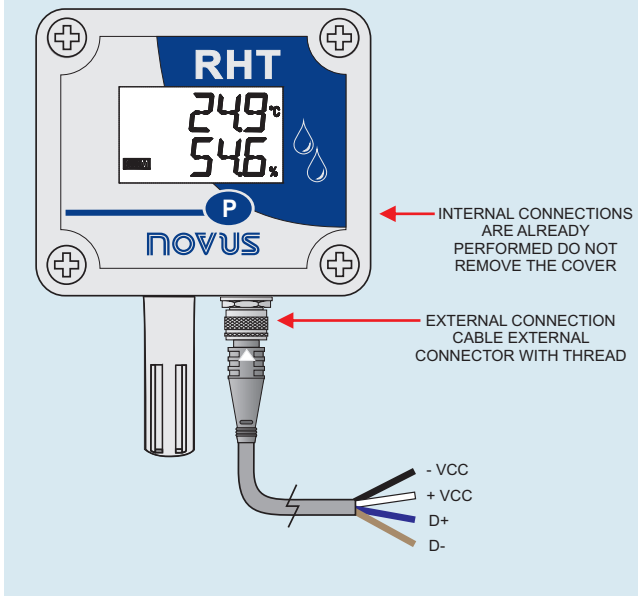

The fixation of the **RHT-DM-485-LCD** model is performed by using a flange. First, the flange is fixed to the duct wall, then the transmitter rod is inserted into the center bore of the flange and fixed. The figure below shows the dimensions and the bore position of this device which can be made of stainless steel or polyamide 6.6.

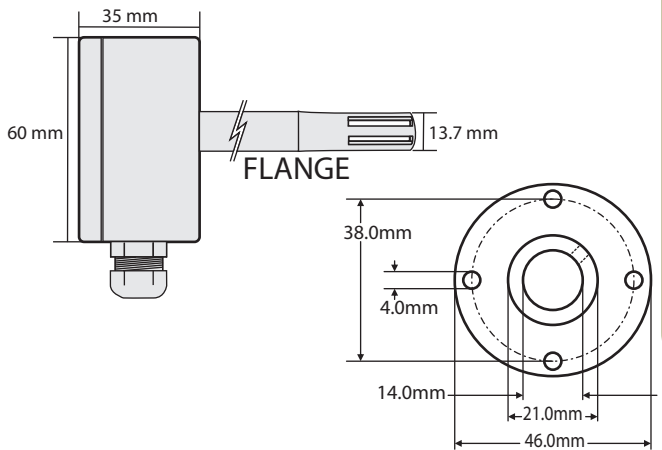

Flange for fixation of the RHT-DM-485-LCD model which comes with the transmitter

HOW TO SPECIFY

MODEL: **RHT Modbus**, where:

- RHT-WM-485-LCD**
- RHT-DM-485-LCD**
- RHT-UP-485-LCD**

- Wall Mount - unique size rod
- Duct Mount - rod having 150 mm or 250 mm
- Under Pressure - connection which supports a pressure difference of up to 10 bar