

TECHNICAL DATA SHEET

PRIMUS Bio→Pharma® – Large Steam Sterilizers

These sterilizers are for customers who require a high quality steam pressure sterilizer whose products, operations and manufacturing facilities are regulated by the FDA. PRIMUS Sterilizers, designed and manufactured in the USA according to Quality Management Systems, are in compliance with ISO9001:2000, ISO 13485 and FDA's Good Manufacturing Practice (GMP) for Medical Devices: General Regulation (21CFR Part 820). Large size sterilizers are one of 19 standard sizes manufactured by PRIMUS, or we can custom manufacture a sterilizer to meet your specifications.



STERILIZER DESIGN

PRIMUS Bio→Pharma® sterilizers are designed for a wide range of sterilizing applications suitable for the laboratory or pharmaceutical industry. Quality materials and workmanship have been incorporated into the chamber, piping and controls to provide a pharmaceutical sterilizer that exceeds industry standards. Bio→Pharma® sterilizers are designed for fully automatic, computer-controlled, operations with vacuum or gravity displacement cycles for terminal sterilization to in-process sterilization of packaging components to production equipment sterilization. Bio→Pharma® sterilizers are the choice when versatility, rigorous tolerances and validatable results are essential. The sterilizer is designed, manufactured and tested at the PRIMUS Bio→Pharma® factory in Omaha, Nebraska USA.

All large sizes of PRIMUS sterilizers have pneumatically powered horizontal operating doors, designed to be efficient, reliable and inherently safe. To close the door, press and hold the door button, if button is released before door is fully closed the door

opens. An added safety feature, the doors stop automatically if an obstacle is encountered.

STERILIZER CYCLES

Standard cycles can be configured through the use of the cycle parameters to process hard goods, wrapped goods or liquid type products. Configuration of the cycle parameters (i.e., number of PRE or POST-PULSES, EXHAUST & DRY, etc.) is unique to each cycle and depends upon the specific product being sterilized. Standard cycles can be designed for steam sterilization of various types of dry goods or liquid products. Dry good products such as filter housings and cartridges, textiles, rubber stoppers or sterilizable plastic packaging may require preconditioning for air removal from the top of flasks. A slow exhaust is used for liquid products with Jacket Off and Flow Cooling selected after exposure to reduce boil-over.

PRIMUS Pri-Matic® controls offer the user access to thirteen password-protected cycles. Cycle parameters for each cycle are baselined, validate and "locked" by validation personnel. Cycle can be custom named to assist and confirm operator selection of correct cycle.



PRIMUS

Sterilizer Company, LLC • 117 South 25th Street • Omaha, NE 68131
Phone (970) 674.1799 • Fax (970) 674-1801 • www.techequipsales.com CO/AZ/NM



PURCHASING SPECIFICATION DATA SHEET

TECHNICAL DATA SHEET

GENERAL (Options italicized)

All models include Vacuum, Gravity and Liquids cycles.

VESSEL MATERIAL AND CONSTRUCTION

The sterilizer features a SA240 TY316L stainless steel (SS) rectangular, horizontal completely jacketed chamber, with fully radiused longitudinal corners which are fully welded and mirror polished to provide the most hygienic, long lasting appearance and durability available. The chamber has a full-length baffle and one drain positioned in the chamber to maximize steam distribution and cross flow within the chamber.

J	26"x63"x48"	N	35"x57"x86"
K	26"x63"x78"	O	49"x57"x86"
L	35"x57"x48"	P	49"x86"x86"
M	35"x57"x60"	Q	61"x86"x86"

The jacket is constructed of SA240 TY304 SS and is mounted to the chamber over channel supports designed to achieve uniform distribution of steam. The jacket enables the stabilization of temperature around the chamber thereby reducing the time required to bring the chamber up to sterilization temperature, providing superior temperature distribution, and preventing the formation of condensation on the chamber walls.

DESIGN and MANUFACTURING APPROVALS

The vessel will be designed and constructed to ASME code Section VIII Division I and pressure rated for 45 PSIG and full vacuum. ASME Code Stamp and U-1 form will bear the name of the specified US manufacturer.

The sterilizer will be manufactured according to Quality Management Systems which are in compliance with ISO 13485 and 9001:2000, will be UL listed and in conformance with CSA requirements.

DOOR CONSTRUCTION

A pneumatically operated horizontally sliding door will be operable from the touchpad push button. To close door, depress/hold door button. If door button is released while door is closing, door reverses direction and opens. In the open position, the insulated door will be secured behind a panel preventing the operator from contact with hot surfaces. An interlock will prevent cycle start unless the door is fully closed and secured.

GENERAL CONSTRUCTION

The vessel will be insulated with 1" semi-rigid high temperature fiberglass board/blanket insulation overlaid with formed aluminum paneling and mounted in a structural steel frame. The frame will be enamel coated and fitted with adjustable legs on self-centering floor pads. The fascia and side panels will be 16-gauge, type 304 stainless-steel,

EQUIPMENT WARRANTY

Sterilizer pressure vessels manufactured by PRIMUS are warranted against defects in workmanship and materials under normal use and operation for fifteen years where the sterilizer is continually maintained under PRIMUS service contract.

SERVICE and EQUIPMENT ACCESS

Standard service access, when facing the unit, will be from left side and top. Wiring will be laid side-by-side and mechanically secured flat against the metal insulation cover. All wiring will be clearly labeled and readily visible for visual tracing. All sterilant piping in the product contact circuit is composed of stainless steel with high quality CLEAN IN Place (CIP), flanged, sanitary fittings. Sanitary pipe clamps are located anywhere CGMP Procedures require frequent maintenance access to process piping to allow ease of routine cleaning and maintenance. Wiring and piping components will be non-proprietary, industry grade, available through Authorized Service Agencies, local supply house, or direct from PRIMUS.

STEAM SOURCE

Steam will be from an in-house steam source in the quantity and quality specified. *Optional electric steam boiler, clean steam boiler or steam-to-steam generator may be specified. Contact PRIMUS for specific boiler information.*

CONTROLS

The Pri-Matic® Control System uses the Allen-Bradley SLC500 Programmable Logic Controller (PLC) with an Allen-Bradley Panel View 1000 Operator Interface Terminal (OIT) and the Pri-Matic® software package to provide automatic cycle operation. The control system hardware is mounted within a separate control cabinet. The system features Pulse Width Modulation (PWM) temperature control. The PLC software meets or exceeds industry standards, is fully documented, validated and maintained under strict configuration control.



PRI-MATIC® CONTROL PANELS WITH PRINTER

HVAC DATA Heat loss, at ambient of 70° F.

	MODEL	KBTU'S/HR
SINGLE DOOR: Through one wall, at fascia	J	5
	K	5
	L	6
	M	6
	N	5
	O	11
	P	19
SINGLE DOOR: Through one wall, service area	J	11.8
	K	12
	L	9
	M	9
	N	9
	O	11.2
	P	17
SINGLE DOOR: Free standing, cabinet total	J	16
	K	16
	L	16
	M	17.5
	N	18
	O	24
	P	36
Q	43	

	MODEL	KBTU'S/HR
DOUBLE DOOR: Through one wall, at fascia	J	5
	K	5
	L	6
	M	6
	N	6
	O	11
	P	19
DOUBLE DOOR: Through one wall, service area	J	16
	K	16
	L	15
	M	15
	N	15
	O	22
	P	33
DOUBLE DOOR: Through two walls, at each fascia	J	5
	K	5
	L	6
	M	6
	N	6
	O	11
	P	19
DOUBLE DOOR: Through two walls, service area	J	10
	K	10
	L	8
	M	10
	N	10
	O	10
	P	14
Q	15.5	

SHIPPING DIMENSIONS, CUBAGE & WEIGHTS

Model Sterilizer Size inches/millimeters	J 26" x 63" x 48" 660.4 x 1600.2 x 1219.2	K 26" x 63" x 76" 660.4 x 1600.2 x 1930.4	L 35" x 57" x 48" 889 x 1447.8 x 1219.2	M 35" x 57" x 60" 889 x 1447.8 x 1524
Shipping Dimensions, Single Door ²	58 x 89.5 x 59.5 1473.2 x 2273.3 x 1511.3	58 x 89.5 x 87.5 1473.2 x 2273.3 x 2222.5	68.63 x 82.5 x 59.75 1743 x 2089.2 x 1517.7	68.63 x 82.5 x 71.75 1743 x 2089.2 x 1822.5
Shipping Dimensions, Double Door ²	58 x 89.5 x 60 1473.2 x 2273.3 x 1524	58 x 89.5 x 88 1473.2 x 2273.3 x 2235.2	68.63 x 82.5 x 60.75 1743 x 2089.2 x 1543.1	68.63 x 82.5 x 72.75 1743 x 2089.2 x 1847.9
Overall Width Dimensions	79 / 2006.6	79 / 2006.6	105 / 2667	105 / 2667
Knockdown Width Dimensions ³	40.5 / 1028.7	40.5 / 1028.7	48.31 / 1227.1	48.31 / 1277.1
Weight, Single Door	CONTACT PRIMUS FOR WEIGHTS			
Weight, Double Door				
Crated Weight (Additional)	VAN DELIVERY ONLY			
Crated Dimensions	42 x 92 x 61 1066.8 x 2336.8 x 1549.4	42 x 92 89 1066.8 x 2336.8 x 2260.6	81 x 87 x 74 2057.4 x 2209.8 x 1879.6	81 x 87 x 86 2057.4 x 2209.8 x 2184.4
Crated Cube	137 cu. ft. / 4 cu. m.	200cu. ft. / 6 cu. m.	302 cu. ft. / 9 cu. m.	350 cu. ft. / 9.9 cu. m.
Loading Equipment	152 lbs/ 69 kg	240 lbs/ 109kg	183 lbs/ 83 kg	380 lbs/ 172 kg
Boiler	785 lbs/ 356 kg	790 lbs/ 359 kg	785 lbs/ 356 kg	790 lbs/ 358 kg

Model Sterilizer Size inches/millimeters	N 35" x 57" x 86" 889 x 1447.8 x 2184.4	O 49" x 57" x 86" 1244.6 x 1447.8 x 2184.4	P 49" x 86" x 86" 1244.6 x 2184.4 x 2184.4	Q 61" x 86" x 86" 1549.4 x 2184.4 x 2184.4
Shipping Dimensions, Single Door ²	69.5 x 82.5 x 97.5 1765.3 x 2089.2 x 2476.5	83.63 x 82.63 x 101.2 2142.2 x 2098.8 x 2570.2	91 x 119.5 x 101.5 2311.4 x 3035.3 x 2578.1	103 x 119.5 x 101.5 2616.2 x 3035.3 x 2578.1
Shipping Dimensions, Double Door ²	69.5 x 82.5 x 98.5 1765.3 x 2089.2 x 2501.9	83.63 x 82.63 x 102.2 2142.2 x 2098.8 x 2595.9	91 x 119.5 x 102.5 2311.4 x 3035.3 x 2603.5	103 x 119.5 x 102.5 2616.2 x 3035.3 x 2603.5
Overall Width Dimensions	105 / 2667	126 / 3200.4	133.5 / 3390.9	145.5 / 3695.7
Knockdown Width Dimensions ³	48.31 / 1227.1	62.38 / 1584.5	70.63 / 1794	82.63 x 2098.8
Weight, Single Door	CONTACT PRIMUS FOR WEIGHTS			
Weight, Double Door				
Crated Weight (Additional)	VAN DELIVERY ONLY		FLAT BED DELIVERY	
Crated Dimensions	82 x 87 x 112 2082.8 x 2209.8 x 2844.8	96 x 87 x 116 2438.4 x 2209.8 x 2946.4	104 x 125 x 117 2641.6 x 3175 x 2971.8	116 x 125 x 117 2964.4 x 3175 x 2971.8
Crated Cube	494 cu ft/ 14 cu m	561 cu ft/ 16 cu m	880 cu ft/ 25 cu m	981 cu ft/ 28 cu m
Loading Equipment	408 lbs/ 185 kg	420 lbs/ 191 kg	460 lbs/ 209 kg	528 lbs/ 240 kg
Boiler	CONTACT PRIMUS			

1. Door beams on all units may be split for shipping purpose.
2. Shipping dimensions are measured to the edge of the heat exchanger and include plumbing on, split beams removed, where applicable, front stainless panel and printer removed.



PRIMUS Bio→Pharma® - Large Sized Autoclaves

SINGLE DOOR

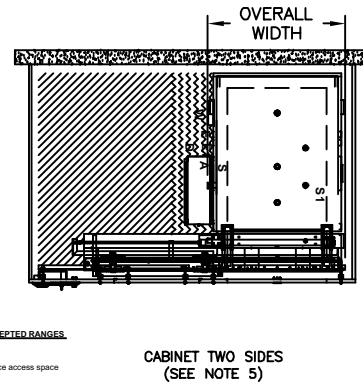
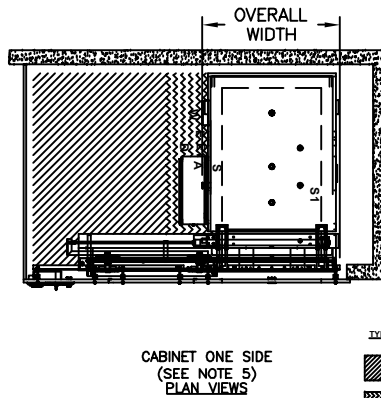
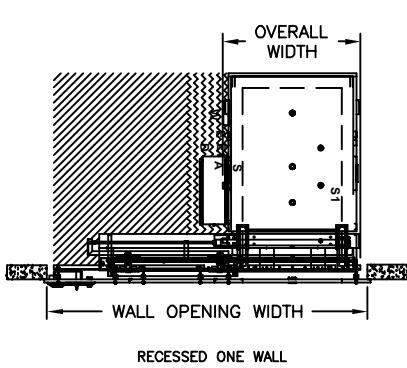
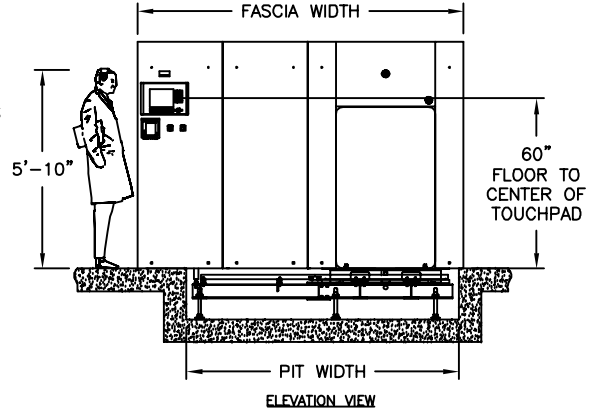
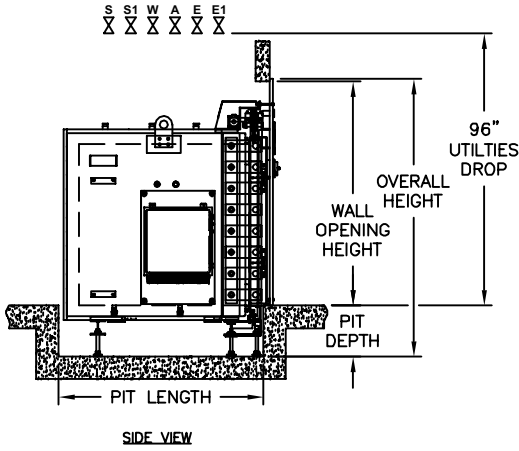

TYPICAL ACCEPTED RANGES

- Service access space
- Typical floor drain and ancillary equipment area.

*Refer to General Arrangement (GA) drawings for details and final connection point to utility services (S-Steam, W-Water, D-Drain, E-Electrical, A-Air).



**VOLUME/DIMENSIONS CHART
SINGLE DOOR**

MODEL	J	K	L	M
Chamber Size (w x h x l) inches/millimeters	26 x 63 x 48 660 x 1600 x 1219	26 x 63 x 76 660 x 1600 x 1930	35 x 57 x 48 889 x 1448 x 1219	35 x 57 x 60 889 x 1448 x 1524
Chamber Capacity	45.5 cu. ft. / 1.29 cu. m.	72.0 cu. ft. / 2.04 cu. m.	55.4 cu. ft. / 1.57 cu. m.	69.3 cu. ft. / 1.96 cu. m.
Overall Width	40.25 / 1022.35	40.25 / 1022.35	52.31 / 1329	52.31 / 1329
Overall Height ¹	109.00 / 2768.6	109.00 / 2768.6	96.00 / 2438	96.00 / 2438.
Overall Length (SD) ²	64.00 / 1625.6	92.00 / 2336.8	63.50 / 1613	75.50 / 1918
Wall Opening Width ³	92.00 / 2337	92.00 / 2337	113.00 / 2870	113.00 / 2870
Wall Opening Height	94.00 / 2387.6	94.00 / 2387.6	83.00 / 2108	83.00 / 2108
Wall Opening Length	62.25/ 1581.15	90.25 / 2292.35	63.50 / 1613	75.50 / 1918
Fascia Width ¹	94.00 / 2388	94.00 / 2388	115.00 / 2921	115.00 / 2921
Fascia Height	95.00 / 2413	95.00 / 2413	84.00 / 2134	84.00 / 2134

MODEL	N	O	P	Q
Chamber Size (w x h x l) inches/millimeters	35 x 57 x 86 889 x 1448 x 2184	49 x 57 x 86 1245 x 1448 x 2184	49 x 86 x 86 1245 x 2184 x 2184	61 x 86 x 86 1549 x 2184 x2184
Chamber Capacity	99.3 cu. ft. / 2.81 cu. m.	139.0 cu. ft. / 3.94 cu. m.	209.7 cu. ft. / 5.94 cu. m.	261.1 cu. ft. / 7.39 cu. m.
Overall Width	52.31 / 1329	66.31 / 1684	73.81 / 1875	85.81 / 2180
Overall Height ¹	96.00 / 2438	96.00 / 2438	137.00 / 3480	137.00 / 3480
Overall Length (SD) ²	101.50 / 2578	105.25 / 2673.4	105.38 / 2677	105.38 / 2677
Wall Opening Width ³	113.00 / 2870	139.00 / 3531	146.00 / 3708	181.00 / 4597
Wall Opening Height	83.00 / 2108	83.00 / 2108	124.00 / 3149.6	124.00 / 3149.6
Wall Opening Length	101.50 / 2578	105.50 / 2680	107.50 / 2730	107.50 / 2730
Fascia Width ¹	115.00 / 2921	141.00 / 3581	148.00 / 3759	183.00 / 4648
Fascia Height	84.00 / 2134	84.00 / 2134	125.00 / 3175	125.00 / 3175

1. Fascia extends 1" beyond wall opening on each side overlapping the wall and top sealing the opening.
2. Allow minimum 2" clearance at rear of recessed unit only. Cabinet side models have rear clearance built in.
3. Contact PRIMUS for alternative wall opening.
4. Standard Left Side Service/equipment access shown. Optional right side access is available.



DOUBLE DOOR

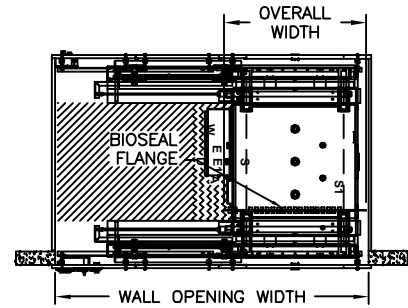
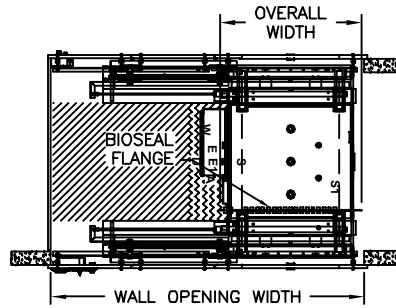
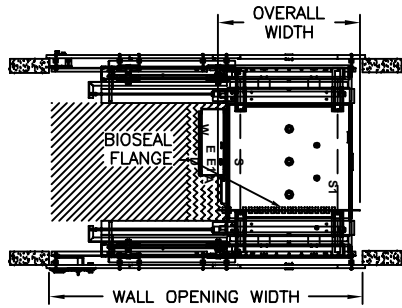
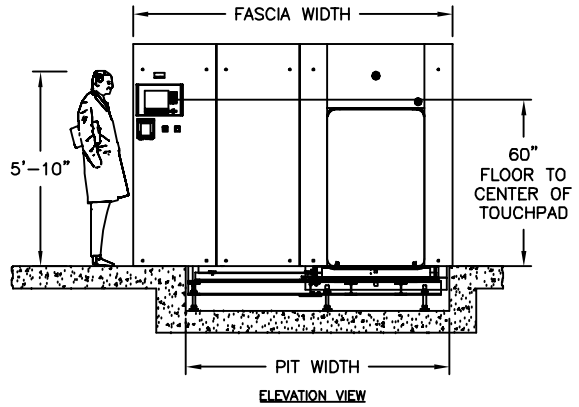
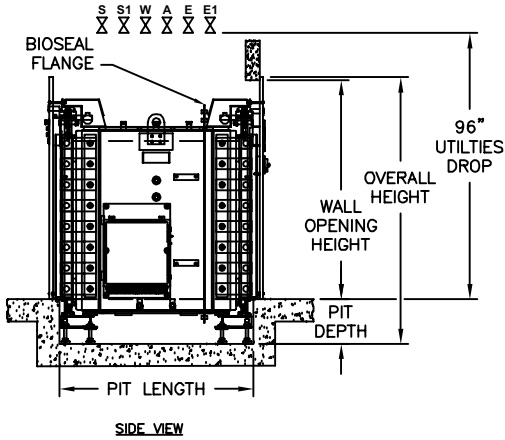

PLAN VIEWS

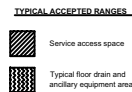

*Refer to General Arrangement (GA) drawings for details and final connection point to utility services (S-Steam, W-Water, D-Drain, E-Electrical, A-Air).



**VOLUME/DIMENSIONS CHART
DOUBLE DOOR**

MODEL	J	K	L	M
Chamber Size (w x h x l) inches/millimeters	26 x 63 x 48 660 x 1600 x 1219	26 x 63 x 76 660 x 1600 x 1930	35 x 57 x 48 889 x 1448 x 1219	35 x 57 x 60 889 x 1448 x 1524
Chamber Capacity	45.5 cu. ft. / 1.29 cu. m.	72.0 cu. ft. / 2.04 cu. m.	55.4 cu. ft. / 1.57 cu. m.	69.3 cu. ft. / 1.96 cu. m.
Overall Width	40.25 / 1022.35	40.25 / 1022.35	52.31 / 1329	52.31 / 1329
Overall Height ¹	109.00 / 2768.6	109.00 / 2768.6	96.00 / 2438	96.00 / 2438
Overall Length (DD)	70.13 / 1781.18	98.13 / 2492.5	67.75 / 1720.9	79.75 / 2025.7
Wall Opening Width ²	92.00 / 2337	92.00 / 23337	113.00 / 2870	113.00 / 2870
Wall Opening Height	94.00 / 2387.6	94.00 / 2387.6	83.00 / 2108	83.00 / 2108
Wall Opening Length	62.44 / 1585.98	90.44 / 2297.18	62.50 / 1587	74.50 / 1892
Fascia Width ¹	94.00 / 2388	94.00 / 2388	115.00 / 2921	115.00 / 2921
Fascia Height	95.00 / 2413	95.00 / 2413	84.00 / 2134	84.00 / 2134

MODEL	N	O	P	Q
Chamber Size (w x h x l) inches/millimeters	35 x 57 x 86 889 x 1448 x 2184	49 x 57 x 86 1245 x 1448 x 2184	49 x 86 x 86 1245 x 2184 x 2184	61 x 86 x 86 1549 x 2184 x 2184
Chamber Capacity	99.3 cu. ft. / 2.81 cu. m.	139.0 cu. ft. / 3.94 cu. m.	209.7 cu. ft. / 5.94 cu. m.	261.1 cu. ft. / 7.39 cu. m.
Overall Width	52.31 / 1329	66.31 / 1684	73.81 / 1875	85.81 / 2180
Overall Height ¹	96.00 / 2438	96.00 / 2438	137.00 / 3480	137.00 / 3480
Overall Length (DD)	105.75 / 2686.1	109.38 / 2778	109.75 / 2788	109.75 / 2788
Wall Opening Width ²	113.00 / 2870	139.00 / 3531	146.00 / 3708	181.00 / 4597
Wall Opening Height	83.00 / 2105	83.00 / 2105	124.00 / 3149.6	124.00 / 3149.6
Wall Opening Length	100.50 / 2553	104.12 / 2645	104.38 / 2651	104.38 / 2651
Fascia Width ¹	115.00 / 2921	141.00 / 3581	148.00 / 3759	183.00 / 4648
Fascia Height	84.00 / 2134	84.00 / 2134	125.00 / 3175	125.00 / 3175

1. Fascia extends 1" beyond wall opening on each side overlapping the wall and top sealing the opening.
2. Contact PRIMUS for alternative wall opening.
3. Standard Left Side Service/equipment access shown. Optional right side access is available.



PRIMUS General Purpose - Large Sized Autoclaves

TECHNICAL DATA SHEET

PIT INSTALLATION DETAILS

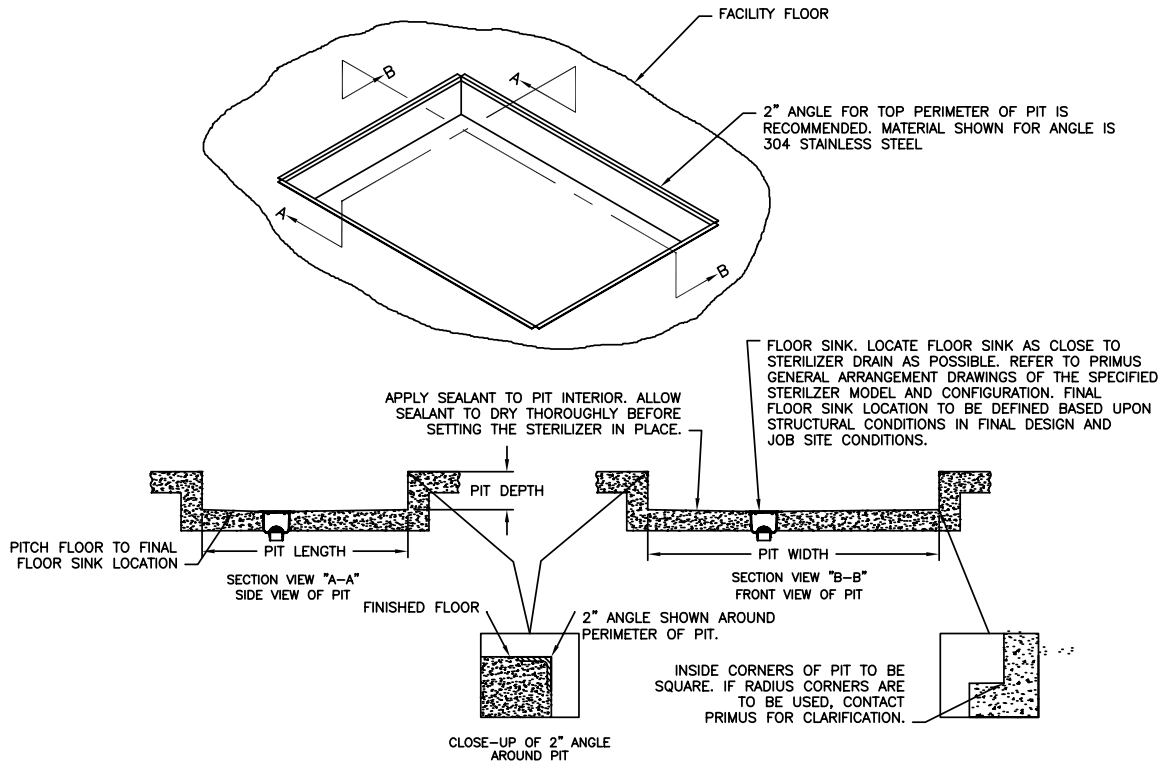

Drawing is a general example of PRIMUS' pit installation. Refer to PRIMUS' General Arrangement (GA) drawings for exact dimensions and pit installation details. Prior to installing your PRIMUS sterilizer verify the pit dimensions are correct with the PRIMUS GA Drawing, ensure the pit is square, clean and sealed. *Contact PRIMUS for further pit installation information.*

PIT DIMENSIONS CHART

MODEL	J	K	L	M
Chamber Size (w x h x l) inches/millimeters	26 x 63 x 48 660 x 1600 x 1219	26 x 63 x 76 660 x 1600 x 1930	35 x 57 x 48 889 x 1448 x 1219	35 x 57 x 60 889 x 1448 x 1524
Pit Depth	12.00 / 304.8	12.00 / 304.8	12.00 / 304.8	12.00 / 304.8
Pit Length (SD)	61.00 / 1569.4	89.00 / 2260.6	61.00 / 1549.4	73.00 / 1879.6
Pit Length (DD)	59.50 / 1511.3	87.50 / 2222.5	59.00 / 1698.6	71.00 / 1803.4
Pit Width	81.00 / 2057	81.00 / 2057	98.00 / 2489	98.00 / 2489

MODEL	N	O	P	Q
Chamber Size (w x h x l) inches/millimeters	35 x 57 x 86 889 x 1448 x 2184	49 x 57 x 86 1245 x 1448 x 2184	49 x 86 x 86 1245 x 2184 x 2184	61 x 86 x 86 1549 x 2184 x 2184
Pit Depth	12.00 / 304.8	12.00 / 304.8	12.00 / 304.8	12.00 / 304.8
Pit Length (SD)	99.00 / 2514.6	101.00 / 2565.4	101.00 / 2565.4	101.00 / 2565.4
Pit Length (DD)	97.00 / 2463.8	97.88 / 2486.5	98.50 / 2501.9	98.50 / 2501.9
Pit Width	98.00 / 2489	130.00 / 3302	138.00 / 3505.2	165.00 / 4191

NOTE: The industry has set 12" as an acceptable pit depth dimension. PRIMUS recommends 12" to 18" depending on the sterilizer size specified to facilitate easier serviceability and maintenance.

ARCHITECTURAL NOTES:

1. Allow sufficient space for traps, shut-off's, filters and other utility supply components.
2. Utility (service disconnects) shall be provided and installed "By Others".
3. Building or structure modifications to accommodate the sterilizer, as well as, sterilizer shoring, rigging, cribbing and/or crane requirements into the facility shall be provided "By Others".
4. Provide maximum mechanical and service access space, a minimum of 24", additional space required when boiler specified. See General Arrangement drawing for placement of ancillary equipment and service access.
5. Some options affect utility services and overall dimensions.
6. Water Quality - Refer to page 12.
7. The Manufacturer's Equipment Warranty does not cover failure due to improper utility provisions.
8. Drawings not to scale.
9. Wall thickness must be provided on single and double door models recessed through 1 wall, with cabinet sides.
10. Electric Vacuum Pump is standard on Models N, O, P and Q.
11. Floor under sterilizer must be water tight and sloped to the drain.

UTILITY SERVICES

Provide utility services within 6'-0" of final connection to sterilizer. Optimum sterilizer performance requires the specified utilities.

MODEL	STEAM (S) Building Steam Supply . Pipe Size: 1" Sanitary*		STEAM (S1) Building Steam Supply . Pipe Size: See Below . Quality: Condensate free 97% to 100% saturated vapor (suitably trapped to ensure dry steam and filtered to remove particulates) . Pressure: 50-80 PSIG Dynamic		WATER (W) Cold Water Supply . Pipe Size: See Below . Temperature: < 70° F . Pressure: 50-70 PSIG Dynamic		DRAIN (D) Building Drain System Minimum 2" . Location: Locate floor sink in service area Note: 1.) Exhaust discharge is cooled to < 140°F 2.) 12" x 12" x 8" floor sink is recommended by PRIMUS 3.) Floor should be sloped to drain		Air Instrument Air . Connection: See Below . Quality: Dry and oil free . Pressure: 60-80 PSI Dynamic		ELECTRICAL (E) Building Power Supply . Volts: 110 . Phase: Single . Amps: 10 Note: Additional circuits are required for ancillary and optional equipment i.e., vaccum pump, boost pump, boiler, etc.	
	TC*	LBS/HR (KG/HR)	NPT	LBS/HR (KG/HR)	NPT	GPM (MAX) (Liter)	NPT (Discharge Pipe Size)		NPT			
J	1"	327.6 (148.6)	1"	36.4 (16.51)	3/4"	14 (53)	1"		1/4"			
K	1"	432.0 (196)	1"	48.0 (21.77)	3/4"	20(75.71)	1"		1/4"			
L	1"	387.0 (175.5)	1"	43.0 (19.50)	3/4"	20(75.71)	1 1/4"		1/4"			
M	1"	432.0 (196)	1"	48.0(21.77)	3/4"	20(75.71)	1 1/4"		1/4"			
N	1"	616.5 (279.6)	1"	685.0 (31.07)	1"	20(75.71)	1 1/4"		1/4"			
O	1"	801.0 (363.3)	1"	89.0 (40.37)	1"	20(75.71)	1 1/4"		1/4"			
P	1"	1089.0 (494)	1 1/2"	1210.0 (54.89)	1 1/2"	20(75.71)	1 1/2"		1/4"			
Q	1"	1296.0 (587.9)	1 1/2"	144.0 (65.32)	1 1/2"	20(75.71)	1 1/2"		1/4"			

ELECTRIC BOILERS

BEBC Electric Heated Boiler - Stainless steel construction for clean steam generation. Includes stainless steel feedwater boost pump.

NOTE: Stainless Steel Boilers shall be operated using only deionized water, having a maximum conductance of 1 microSeimen per cm (1 μ S/cm) [minimum specific resistivity of 1 megohm per cm (1MW/cm)].

MODEL		J	K	L	M
Chamber Size (w x h x l) inches/millimeters		26 x 63 x 48 660.4 x 1600 x 1219	26 x 63 x 76 660.4 x 1600 x 1930	35 x 57 x 48 889 x 1148 x 1219	35 x 57 x 60 889 x 1448 x 1524
Boiler Size	kW/Hr.	144.0	180.0	158.0	180.0
Boiler Steam Output	lbs./Hr	433.0	542.0	475.0	542.0
Stand Alone	Model	EB-J	EB-K	EB-L	EB-M
V.A.C. 208, 3 Ph	Amperes	400	N/A	N/A	N/A
V.A.C.240, 3 Ph	Amperes	347	434	379	434
V.A.C. 480, 3 Ph	Amperes	173	217	190	217
V.A.C. 110, 60 Hz. ¹	Amperes	10	10	10	10
MODEL		N	O	P	Q
Chamber Size (w x h x l) inches/millimeters		35 x 57 x 86 889 x 1448 x 2184	49 x 57 x 86 1245 x 1448 x 2184	49 X 86 X 86 1245 x 2184 x 2184	61 X 86 X 86 889 X 1448 X 1524
Boiler Size	kW/Hr.	240.0	360.0	450.0	540.0
Boiler Steam Output	lbs./Hr	723.0	1054.0	1355.0	1656.0
Stand Alone	Model	EB-N	EB-O	EB-P	EB-Q
V.A.C. 208, 3 Ph	Amperes	N/A	N/A	N/A	N/A
V.A.C.240, 3 Ph	Amperes	578	N/A	N/A	N/A
V.A.C. 480, 3 Ph	Amperes	289	434	542	650
V.A.C. 110, 60 Hz. ¹	Amperes	10	10	10	10

1. Controls Current
N/A - Not Available

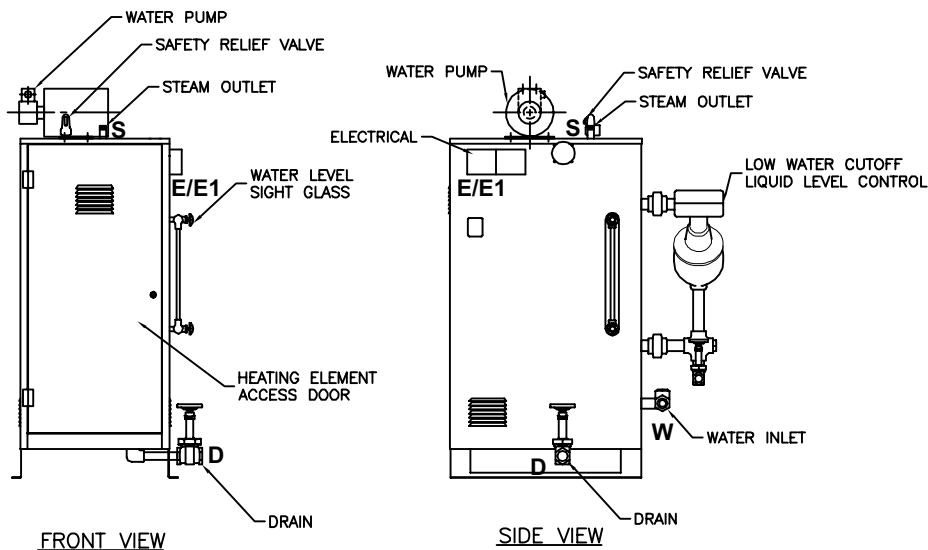

STEAM TO STEAM GENERATOR (SCS1 & SCS2)

Steam to Steam Generator used to generate either clean or pure steam. The preferred method of generating Clean or Pure steam, when house steam is available to drive the generator. Converts to steam, whatever quality water is delivered.

BSCS1 Pure Steam - stainless steel steam to steam generator with sanitary fittings, double tube sheet construction. Generated from WFI quality depyronated water. The water source to the Pure Steam Generator is either house generated or "By Others".

BSCS2 Clean Steam - stainless steel steam to steam generator with threaded fittings, threaded connections and single tube construction. Generated from distilled or reverse osmosis water. Clean Steam sterilizers normally include stainless steel piping for all wetted surfaces in the product loop.

NOTE: Refer to Page 12 for information on Water Quality.
 Refer to the boiler/steam to steam generator maintenance manual provided with the sterilizer prior to using any boiler treatment chemicals.
 Contact PRIMUS for further recommendations.

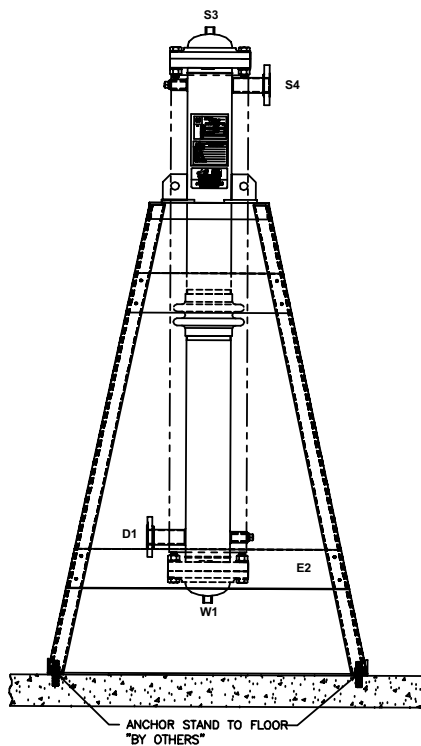
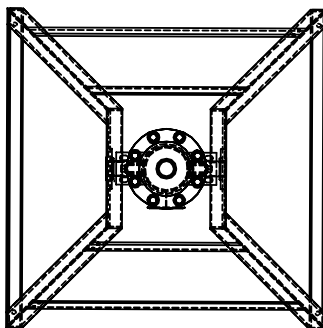

Use the following pages to custom design your sterilizer by checking the boxes of the configuration and options required for your project. Transfer all items checked to the Specification Worksheet (Pages 19 & 20) and fax to PRIMUS Sales Department or to your local Sales Representative for a quotation. If you do not find an option or size listed to meet your requirements, please contact our Project Manager for additional information and assistance.

Model Number Notation

SD = Single Door
DD = Double Door
↓

PSS - -M - -

↑ ↑ ↑

Pri-Matic = 6 J
ControlLogix = 7 K

L
M
N
O
P
Q

S = House Steam
E = Electric Boiler
P = Steam to Steam

Five models are offered:

- J - 26" x 63" x 48"
- K - 26" x 63" x 76"
- L - 35" x 57" x 48"
- M - 35" x 57" x 60"
- N - 35" x 57" x 86"
- O - 49" x 57" x 86"
- P - 49" x 86" x 86"
- Q - 61" x 86" x 86"

A detailed formatted specification, suitable for inclusion in formal contract documents, is available on request.

Note: Use the above format to determine PRIMUS Model number and insert below and on Page 19, Specification Worksheet.

PRIMUS General Purpose Steam Pressure Sterilizer, Model Number PSS _____.

SELECT CONFIGURATION

Door

- BGDA - Single Door
- BDB - Double Door

Cabinet

- BCD - Panels Both sides
- BCCL - Left Side Panel
- BCCR - Right Side Panel

Recessed

- BCA - One wall
- BCB - Two walls

Service and Equipment Access

- Left Side (Standard)
- Right Side

Steam Source

- | | | |
|---|---|---|
| <ul style="list-style-type: none"> <input type="checkbox"/> House Supply | <ul style="list-style-type: none"> <input type="checkbox"/> Clean Steam² <ul style="list-style-type: none"> <input type="checkbox"/> BEBC1 - 208/3 phase³ <input type="checkbox"/> BEBC2 - 240/3 phase³ <input type="checkbox"/> BEBC3 - 480/3 phase³ <input type="checkbox"/> Other _____ <input type="checkbox"/> BEB0⁵ - Auto Blowdown | <ul style="list-style-type: none"> <input type="checkbox"/> Steam to Steam² <ul style="list-style-type: none"> <input type="checkbox"/> BSCS1 - Pure Steam Dbl Tube <input type="checkbox"/> BSCS2 - Clean Steam Sgl Tube <input type="checkbox"/> BSCS⁴ - Clean Steam Sgl Tube Sanitary <input type="checkbox"/> Other _____ |
|---|---|---|

1. Electric boilers are available in Carbon Steel or Stainless Steel.
2. Contact PRIMUS for overall dimensions and utility connections.
3. All models are stand-alone.
4. GMP Validatable Option Only, sanitary piping required.
5. Low Water Cutoff is standard and the "automatic reset" feature is disabled with this option. The boiler will need to be manually rest.
6. Water Quality - For best results, feed water supply should be evaluated prior to initial startup to ensure it is of the quality necessary for the application, various external treatment processes (water softener, water conditioning, etc.) may be used. Contact PRIMUS for further recommendations.

PHARMACEUTICAL CONFIGURATIONS

Clean Steam Sterilizers BP9

For cell/tissue culture applications. This option provides direct connection to a house-source of clean steam. Includes threaded stainless piping and components to chamber. If clean steam is only steam source, specify option BP9.1 for stainless piping to jacket. For alternate sources to generate clean steam, specify electric clean steam boilers (stainless steel), or when house steam is available, specify steam-to-steam generators. (Stainless steel heat exchanger).

BP9	Stainless piping to chamber - threaded
BP9.1	Stainless piping to jacket - threaded
BEBC	Clean Steam Stainless Electric Boiler (specify voltage)
BSCS1*	Pure Steam Double Tube Sheet, Sanitary Connections
BSCS2*	Clean Steam Single Tube Sheet with threaded connections
BSCS3*	Clean Steam Single Tube, Sanitary Connections

*Contact PRIMUS for alternate steam generator options.

Air-over Cooling BP11

Provides a means of rapidly cooling sterilized load. Effective to decrease cycle times with liquid loads. Filtered ambient air displaces steam during exhaust cycle to rapidly cool load and prevent boil-over.

CLEAN-IN Place Piping BP15

CLEAN-IN Place (CIP) piping is standard for all piping in the product contact circuit. CIP piping has an interior finish <25 μ Ra.

Control Cycle on Load Temperature BC24

Use to establish the most beneficial cycle temperature and exhaust rate parameters. Monitors and controls the load temperature. Use to establish best parameters for liquid loads and for loads with complex geometries and a tortuous path for steam penetration.

Note: See additional Bio-Containment Options

CONTROLS AND RELATED OPTIONS

(Contact PRIMUS for details and performance specifications)

PSS6 Pri-Matic® Control BC1

Pri-Matic® Control System PSS6 uses the Allen-Bradley SLC 500 Programmable Logic Controller (PLC) with an Allen-Bradley Panel View 1000 Operator Interface Terminal (OIT) and the Pri-Matic® software package to provide automatic cycle operation. Pri-Matic® shall offer a total of fifteen (15) cycles, with thirteen (13) standard cycles available for product sterilization. Standard cycles are configurable by modifying the cycle parameters for each. Two dedicated cycles are available for performing vacuum leak test and sterilize filter.

PSS7 Control System BC1.1

PSS7 uses the Allen-Bradley ControlLogix PLC with Ethernet connectivity and PanelView Plus OIT in place of the SLC500 PLC and standard PanelView. ControlLogix provides graphical color touch screen capability, real time process graph, active Plumbing & Instrumentation Diagram (P&ID) screens and the ability to standardize control systems throughout a facility. PSS7 offers a total of fifteen (15) cycles with thirteen (13) standard cycles available for product sterilization. Standard cycles are configurable by modifying the cycle parameters for each. Two dedicated cycles are available for performing vacuum leak test and sterilizer filter.

PSS8 Trinity Control System BCT

PSS8 microcomputer with a selection of twenty-five (25) separate programs for sterilization of wrapped goods, hard-goods, liquids and test cycles. Trinity Controller has a color touch sensitive screen with 30 line x 40 character display mounted on the front fascia with a thermal printer. Help screens for programming and trouble shooting alarm conditions. Cycle data can be printed, captured to a remote personal computer or logged to memory.

Sterilization Based on Accumulated F₀ BC2

When sterilization based on accumulated heat lethality F₀ is selected, exposure length is based on a settable value for the total accumulation of F₀ during the charge and exposure phases. The accumulated F₀ value must be reached before the sterilization phase is completed.

Supervisory Control and Data Acquisition (SCADA) System BC8

The optional SCADA Interface provides the end user with a structured data format which can be easily interfaced with control room processes.

Remote Record of Run Data BC11

Supervisory use to capture electronic record of each sterilization cycle. Cycle hard copy and display data is transmitted via RS232 in real time to remote computer, up to 100 feet away, for display and recording. Hard copy records may be printed from the computer. Available on both control systems.

CONTROLS AND RELATED OPTIONS (CONT'D)

- Sterilize Filter Cycle BC13**
Sterilize filter is a stand-alone cycle used to sterilize the 0.2 micron sterile air filter, filter housing and related piping.
- Authorized Operator Access BC32**
Restricts operation of sterilizer to authorized personnel and provides supervisor with PIN number of person running the cycle. Access levels are available for administrator, supervisor and operator level groups.
- Remote Mount Control Panel BC10**
Mount control panel in separate housing adjacent to or up to 100 feet away from the sterilizer. Available on both control systems.
- Thermal Printer BR7**
Thermal dot-matrix printer with take-up reel and 32 characters per line printing is standard. Second sterilization cycle report available at the end of the run.

BIO-CONTAINMENT OPTIONS

- BioSeal Flange BV6**
Provides a means of isolating load from the unload ends of the sterilizer. A vapor-proof flange is welded to the vessel on both sides of the flange and around its full circumference. Penetrations through the flange for electrical and piping components are secured with vapor proof fittings. Optional on single door units, standard on double door units.
- BioSeal Panels BV7**
Aluminum panels for attachment to, and extending from, the BioSeal Flange to adjacent building surfaces to complete the barrier between either end of the sterilizer.
- | | | |
|--|------|-------------------------------------|
| | BV10 | Stainless steel in lieu of aluminum |
|--|------|-------------------------------------|
- BioSeal Fully Welded Box BV11**
Provides a fully welded stainless box, welded to the BioSeal flange forming the complete BioSeal. Check proposed installation site. Install into wall opening with end-opposite box BioSeal, first. For double-door pass-through model B requiring a Box BioSeal and a boiler, specify a stand-alone boiler .
- Conax Adapter BC5**
Provides two (2) 316L SS CIP chamber penetration, for validation purposes. Conax Adapter provides a compression gland inside the port, through which 1-24 thermocouple leads are fed to the chamber interior.
- Remote Signaling of Sterilizer Status BC23**
Control relay connection enabling operation of a remote signaling devise for an alarm condition. Alarm conditions many include Door Open, Door Closed and Cycle complete. Signal may be used to activate a buzzer, light or any other On-Off device.
- Compress Air to Gasket BP10**
Compressed air is used to seal gasket against door interior during cycles on Bio→Pharma® sterilizers. Prolongs gasket life. Requires compressed air utility service, or option BEAC air-compressor. Optional steam to gasket is available.

GENERAL OPTIONS

Validation Port, 2 inch BV5

Provides chamber penetration to accommodate various monitoring/control probes. Standard on B, C, and D models.

Seismic Restraints BV8

Required in areas prone to seismic hazards. Secures sterilizer to building but allows for leveling. Designed to current California Code.

Electric Vacuum Pump BP4

A water-sealed electric vacuum pump is standard on sanitary sterilizers providing a vacuum, in lieu of the standard water ejector on non-sanitary sterilizers. Check PRIMUS' General Arrangement drawing to assure the required ancillary equipment space is provided.

Drain Line Strainer/Valve BP25

Provides a means to trap and expel debris from the chamber drain line to protect heat exchanger from damage.

Floor Mounted BFM

Replaces standard Pit Mount. Special order 'Floor Mounted' with ramp or carriage/cart.

Air Compressor BEAC

For small size sterilizers, (less than 75 cu. ft.), air compressor mounted on sterilizer frame, for use when house supplied air is required but not available. Not available if Air-Over Option BP11 is specified.

UTILITY - STANDARD FEATURES

Quench Effluent on Demand to Drain BP6

Assures effluent exhausted to drain is 140°F or below, provides quench water for exhaust effluent only on demand, to conserve water. Standard on all units.

Stepping Transformers BE1

Reduces line voltage to required 110 VAC for operation of sterilizer controls.

BE1A	220 vac to 110 vac
BE1B	480 vac to 110 vac
BE1C	480/240/240/120, 1 phase, 0.5 KVA

Uninterruptible Power Supply BE2

In the event of electrical power loss and no emergency electrical power to sterilizer, this option provides electrical power to operate control system for up to 30 minutes, to complete the cycle. This option is dedicated power source for the electronic controls only and will not supply any power requirements for heavy power load components (boiler, pumps, compressors, etc.).

Chilled Water Recirculation (Conservation System) BP24

Provides water conservation through the use of Chilled Water versus City Water to cool drain effluent. Additional water conservation is provided by reusing the cooled drain effluent for the water ring seal on the vacuum pump.

LOADING EQUIPMENT

Loading cart includes one bottom and one intermediate shelf with four adjustable levels. Additional shelves are available. Cart frames and shelves are 316L stainless steel welded, ground and polished. Shelf surfaces are stainless steel wire mesh. Transfer carriages include swivel casters with swivel locks and 5" wheels with wheel brakes. Loading cart and transfer carriages are recommended for chamber lengths greater than 48". Pit Mounted units with chamber length equal or great than 60" use one set of 2 floor carts.

BL4	Loading Cart
BL5	Additional Cart Shelf
BL6	Transfer Carriage
BL7	Floor Cart
BL8	Additional Floor Cart Shelf

NOTE: Loading cart and transfer carriages are recommended for chamber lengths 48 inches or longer. Pit Mounted units with chamber length equal or greater than 60" use one set of 2 floor carts.

Contact PRIMUS for special loading equipment requirements. Existing loading equipment may be able to be retained, contact PRIMUS for more information.

LOADING EQUIPMENT (cont'd)

FLOOR LOADER CART DIMENSIONS

CHAMBER SIZE	MODEL	FLOOR CART QTY	A	B1	B2	C	D
J - 26"x 63"x 48"	L7-J	1 - L7	24"	53.82"	60.19"	46"	16"
K - 26"x 63"x 76"	L7-K	2 - L7	24"	53.82"	60.19"	36.5"	16"
L - 35"x 57" x 48"	L7-L	1 - L7	33"	46.88"	53.18"	46"	25"
M - 35"x 57"x 60"	L7-M	1 -L7	33"	46.88"	53.18"	28.5"	25"
N - 35"x 57"x 86"	L7-N	2- L7	33"	46.88"	53.18"	41"	25"
O - 49"x 57"x 86"	L7-O	2- L7	47"	46.88"	53.18"	41"	39"
P - 49"x 86"x 86"	L7-P	2- L7	47"	72"	78.38"	41"	39"
Q - 61"x 86" x86"	L7-Q	2- L7	59"	72"	78.38"	41"	51"

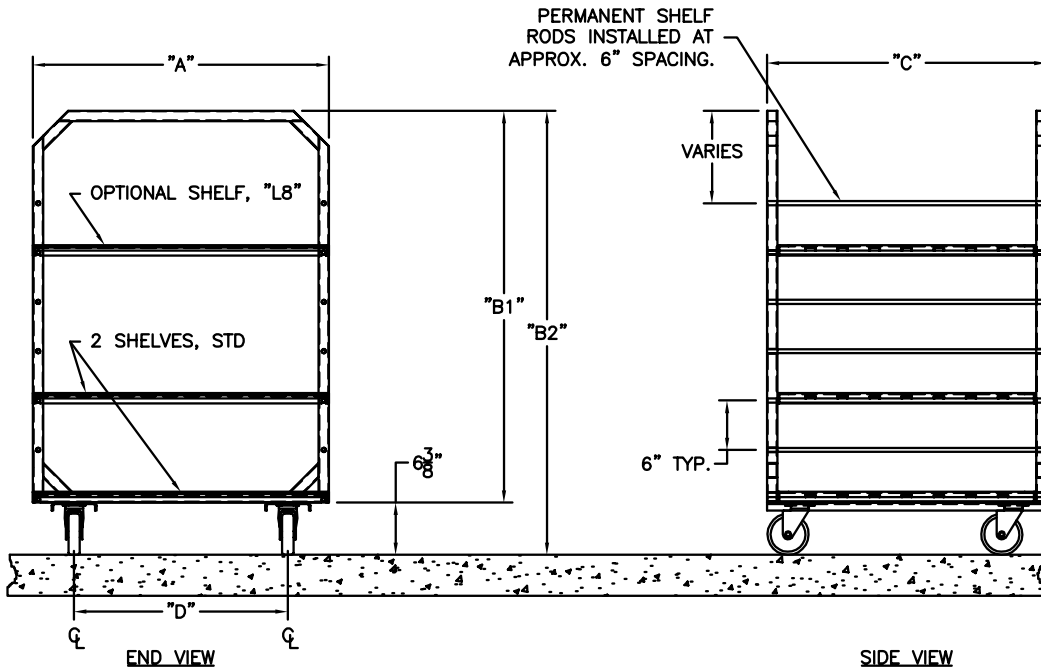

The PRIMUS Difference:

- Quality and Innovation – Dedicated to sterilizers for over 25 years.
- Steam Sterilizers are Our Only Business – Proud to be the only major steam sterilizer manufacturer specializing in Steam Sterilizers
- ASME Certified Pressure Vessel Factory – Being the owner of our ASME shop ensures highest of quality and faster deliver times
- USA Designed and Manufactured
- 19 Standard Sizes, Custom Sizes Available
- Steam Sterilizer for Every Need – From Basic Sterilization to Hazardous Waste, to Validatable Pharmaceutical and Bio-Critical Applications
- Engineered the Service Out of Sterilizers – “Making it one of the easiest in the industry to service” per our Authorized Service Agents and Customers
- Simplicity of Design – less parts to fail
- Non-Proprietary Components – Lowers the cost of ownership, minimizes down time and provides a more efficient meantime repair
- 304 Stainless Steel Fully Jacketed Vessel (no laminates) – reduces heat-up time and loss of temperature, providing greater uniformity of chamber temperature
- Rectangular Chamber - eliminating wasted space and high utility cost
- Sliding Doors: Inherently safe doors – seal integrity. Not a burn hazard
- PRIMUS Controls with “Evergreen Migration” meaning the hardware and software is continually supported lowering total costs of ownership – All controls offer multiple options on 4 different control platforms. Through constant improvements and development PRIMUS Controls remain a leader in the industry. Simple to operate, reliable and versatile.
- Vacuum, Gravity, Liquid and Test Cycles - Standard on all Sterilizers
- Pri-Mirror® Chamber Finish – Most sanitary in the industry. Providing a mirror finish of <10 Micro Inches Ra, the result is a non-porous surface easy to clean and hostile to microorganism
- Independent Dealers, Sales Representatives and Authorized Service Agents Worldwide – offering the most coverage and flexibility
- Customer Service - Important part of PRIMUS offered through our Authorized Service Agents or directly from PRIMUS’ Service Department
- Turn Key Operation – from planning to installation to start-up and training
- FDA, ISO 9001:2000, ISO13485-2003; UL Listed, ASME Section VIII Division I, Health Canada License

PRIMUS sterilizers represent state-of-the-art technology, built to the highest standards thanks to employees who have a strong work ethic and dedication to craftsmanship. Quality products and personal service is first and foremost with PRIMUS.

PRIMUS has earned a reputation for offering the premier sterilizer on the market!

***“PRIMUS Sterilizer...
...Quality by Design, Excellence by Choice”***



Three 26” x 63” Pit-mounted Units

***QUALITY AND INTEGRITY FORM THE FOUNDATION OF
PRIMUS STERILIZER COMPANY
OUR VISION FOR CONTINUAL IMPROVEMENT IS REALIZED
THROUGH THE ESTABLISHMENT OF QUALITY OBJECTIVES
ACHIEVED THROUGH TEAMWORK WITH A GOAL OF
RETURNING SIGNIFICANT VALUE TO OUR CUSTOMERS.***

This document and data contained within is intended for the exclusive use of PRIMUS customers, including architects or designers. It shall not be reproduced in whole or in part without permission of PRIMUS Sterilizer Company, LLC. Any authorized reproduction must bear the entire page to include Headers and Footers.



PRIMUS Sterilizer Company, LLC • 117 South 25th Street • Omaha, NE 68131
Phone (970) 674.1799 • Fax (970) 674-1801 • www.techequipsales.com CO/AZ/NM



PRIMUS Technical Data Worksheet

Complete the following by selecting the options or transferring the options, checked on preceding pages, required to meet your needs. Tear off and forward completed worksheet to PRIMUS Sales Department, fax 402-344-4251, or your local PRIMUS Representative. If you do not find an option or size listed to meet your requirement, please contact our Sales Department for additional information and assistance with a custom design to meet your specifications.

PRIMUS MODEL NUMBER		QUANTITY	
PROJECT NAME			
PROJECT ADDRESS			
COMPANY NAME		PHONE	
CONTACT NAME		FAX	
CONTACT EMAIL			
SPECIFICATION SECTION		ITEM NO.	
SHOWN ON DRAWING NO.		ROOM NO.	
PRIMUS QUOTE NO.			

GENERAL CONFIGURATIONS	
BDA	Single Door
BDB	Double Door
BDE	Door(s) Manually Operated (Std)
BCD	Cabinet, 2 sides
BCCL	Cabinet, 1 Side Left
BCCR	Cabinet, 1 Side Right
BCA	Recessed, 1 Wall
BCB	Recessed, 2 Wall
NPN	Left Side Service (Std)
BC30	Right Side Service Access & Control
BC31	Control Panel Opposite Side of Service
BCF	Rear Panel
BCG	Hinged Access Panel thru Fascia
STEAM SOURCE	
BEB1	Boiler, 208/3ph
BEB2	Boiler, 240/3ph
BEB3	Boiler, 480/3ph
BEBC1	Clean Steam, 208/3ph
BEBC2	Clean Steam, 240/3ph
BEB3	Clean Steam, 480/3ph
BSCS1	Pure Steam Double Tube, Sanitary
BSCS2	Clean Steam Single Tube
BSCS3	Clean Steam Single Tube, Sanitary
BEBO	Automatic boiler blow-down
BIWC	Low Water Cutoff, Manual Reset
PHARMACEUTICAL OPTIONS	
BP9	Clean Steam to Chamber, Threaded Piping
BP9.1	Clean Steam to Jacket, Threaded Piping
BP11	Air-Over Cooling
BC24	Control Cycle on Load Temperature
CONTROLS & RELATED OPTIONS	
BC1	Pri-Matic Control System, PSS6
BC1.1	Pri-Matic Control System, PSS7 (ControlLogix)
BC2	Pri-Matic F ₀ control F ₀ accumulated, 4 points
BC8	SCADA Data File

CONTROLS & RELATED OPTIONS (con't)	
BC11	Serial Data Output
BC13	Sterilize Filter Cycle
BC32	Authorized Operator Access
BC10	Remote Mount Control Panel
BR7	Thermal Printer, Take-up Reel (Std)
BR7	Thermal Printer, 32 Character (Std)
BIO-CONTAINMENT OPTIONS	
BV6	One BioSeal Flange
BV7	BioSeal Extension Panels
BP10	Compressed Air to Gasket
BC5	Conax Adapter
BC23	Remote Alarm Signal
BV11	Fully Welded BioSeal Box
GENERAL OPTIONS	
BV3.1	Validation Port, 1.0" diameter
BV8	Seismic Restraint
BP4	Electric Vacuum Pump (Std)
BP25	Drain Line Strainer/Valve
BDF	Automatically Operated Door
BEAC	Air Compressor
UTILITY - RELATED OPTIONS	
BP6	Quench Water to Drain, on Demand (Std)
BE1A	Stepping Transformer from 220V to 110V
BE1B	Stepping Transformer from 480V to 110V
BE1C	Stepping Transformer from 480/240-240/120V, 1 ph, 0.5KVA
BE2	UPS maintains sterilizer operation for 30 minutes during power outage
BE3	GFI Receptacle

Std = Standard Component
 SS = Stainless Steel
 CIP = Clean-in-Place
 N/A = Not Available

(Continue on the next page)

Technical Data Worksheet (con't)

LOADING EQUIPMENT	
BL1	Removable Bottom Shelf (Std)
BL2	Extendable Bottom Shelf
BL3	Additional Chamber Shelves
BL4	Loading Cart
BL5	Additional Cart Shelves
BL6	Transfer Carriage
BL7	Floor Cart (chamber lengths greater than 60" use 1 set of 2 floor carts)
BL8	Additional Floor Cart Shelves
OTHER CONTROL OPTIONS	
BC3	Blind Flange Assembly, Sanitary Fitting
BC4	Jacket Pressure Display, Digital
BC5	16/24 Thermocouples Conax Adapter
BC7	Second PanelView 1000
BC14	WFI Interface
BC15	Pri-Matic in NEMA 12 ¹ enclosure (Dustproof)
BC15.1	Stainless Steel Enclosure for Pri-Matic Control Panel
BC16	Pri-Matic mounted in NEMA 4 ² Enclosure (Waterproof)
BC16.1	Pri-Matic mounted in NEMA 4X ³ SS Enclosure
BC17	Remote Sterilizer "OFF" Signal
BC18	Remote Sterilizer "In-Cycle" Signal
BC23	Remote Alarm Signal
BC26	PanelView 550, Service Area
BC29	Additional Operational Manuals (2 hard copies and 1 CD provided) Qty _____
BC30	Modem PLC
BC31	Second RTD Load Probe
BR2	Dot Matrix Printer, 80 column
BR3	Strip-Chart Recorder
BR4.1	Thermal Printer, Flush Mount 24 Col.
BR5	Circular Chart Recorder
BR6	Impact Printer, 24 Column

OTHER PIPING OPTIONS	
BP1	Heated Air-In, Heat Exchanger SS
BP5	Safety Valve Over Rupture Disk
BP15	CIP Piping (Std)
BP16	Air to Jacket Cooling
BP18	Passivate Chamber
BP19	Passivate Chamber and Piping
BP20	Steam Quality Sampler
VESSEL OPTIONS	
BV1	Stainless Steel Frame
BV2	Jacket Type, 316 L SS
BV3	Jacket Insulation Cover, SS
BV6.1	Additional BioSeal Flange
BV8	Seismic Restraints
BV10	BioSeal Panels, Stainless
GMP DOCUMENTATION OPTIONS	
BD1	GMP Validation Documentation
BD2	IQ/OQ Protocol, PSS500
BD3	IQ/OQ Protocol, Pri-Matic

Std = Standard Component
 SS = Stainless Steel
 CIP = Clean-in-Place
 N/A = Not Available
 1 = NEMA 12 (IP55), Dustproof, Painted Steel Enclosure
 2 = NEMA 4, Waterproof, Stainless Steel Enclosure
 3 = NEMA 4X (IP66), Waterproof, Stainless Steel Enclosure

YOUR LOCAL PRIMUS REPRESENTATIVE:

 Technical Equipment Sales Inc. <i>Manufacturers Representatives</i>	
<p>Arizona Office</p> <p>Gary Carlin 15811 Palisades Blvd. Fountain Hills AZ 85268 PH: 480.816.1514 Mobil: 480.816.1590 gcarlin@techequipsales.com</p>	<p>Colorado Office</p> <p>Mike Crowe PO Box 281 Severance CO 80548 PH: 970.674.1799 Mobil: 303.809.5556 mcrowe@techequipsales.com</p>

FOR ADDITIONAL ASSISTANCE

To discuss your sterilization design needs, please contact PRIMUS.

Manufacturer reserves the right to modify materials or specification without notice.

