

1. INSTALLATION

The controller must be installed in panels with square slots. To fix it, insert the controller in the panel slot through the front side and fix the clamps on the controller body through the rear end of the panel. Press the clamps tightly to fix the controller on the panel.

You can withdraw the internal part of the device from its case through the panel front side, it is not necessary to remove the case, the clamps or connections. Pull firmly the controller from the front panel and it will leave the case.

2. SPECIFICATIONS

- Dimensions 96 x 96 x 90 mm. Panel slot 93 x 93 mm. Weight: 11.64 oz
- Power supply: 100 to 240 Vac/dc, 50 / 60 Hz, Optional: 24 Vdc (15 to 30 Vdc/ac); Consumption max: 9 VA.
- Environmental conditions: 5 to 50 °C; Relative humidity (maximum): 80 % up to 30 °C. For temperatures above 30 °C, decrease 3 % per °C. Installation category II. Pollution degree 2. Altitude < 2000 m.
- Sensor input Pt100 ($\alpha=0.00385$) Three-wire connection excitation: 170 μ A
- Thermocouple sensor input: Input impedance 10 M Ω .
- A/D converter resolution: 15000 levels
- Sampling rate: 10 measures/second
- Front Panel: Polycarbonate UL94 V-2; Back Panel: ABS + PC UL94 V-0
- EMC: EN 61326-1:1997 and EN 61326-1/A1:1998
- SAFETY: EN61010-1:1993 and EN61010-1/A2:1995
- Accuracy: 0.20 % of the maximum range ± 1 °C for Pt100,
0.25 % of the maximum range ± 1 °C for Thermocouple,

The thermocouples must be connected to the 11 and 12 pins, observing polarity. A compensation or extension cable is required.

Pt100 sensors must be 3-wire connected to terminals 10, 11 and 12 as **Figure 1** shows. For an adequate cable resistance compensation, all the conductors must have the same electrical resistance. If the Pt100 is a 4-wire sensor, leave one disconnected by the controller. For 2-wire Pt100, use a jumper in the 10 and 11 terminals of the controller (in this case, there is no auto compensation of the cables length, 1 °C is added to each 0.4 Ω of the total cable resistance).

Table 1 shows the different types of temperature sensor the controller can accept and the keypad code for their selection.

TYPE	CODE	FEATURES
J	0	range: -50 to 760 °C (-58 to 1400 °F)
K	1	range: -90 to 1370 °C (-130 to 2498 °F)
T	2	range: -100 to 400 °C (-148 to 752 °F)
N	3	range: -90 to 1300 °C (-130 to 2372 °F)
R	4	range: 0 to 1760 °C (32 to 3200 °F)
S	5	range: 0 to 1760 °C (32 to 3200 °F)
Pt100 (Resolution 0.1 °C)	6	range: -199.9 to 530.0 °C (-199.9 to 986.0 °F)
Pt100 (Resolution 1 °C)	7	range: -200 to 530 °C (-328 to 986 °F)

Table 1 – Sensors the controller is able to accept

2.1 POWER SUPPLY

Power is supplied through the terminals 13 and 14. Check the voltage written on the device box.

2.2 ELECTRICAL CONNECTIONS

Figure 1 shows the controller electrical connections.

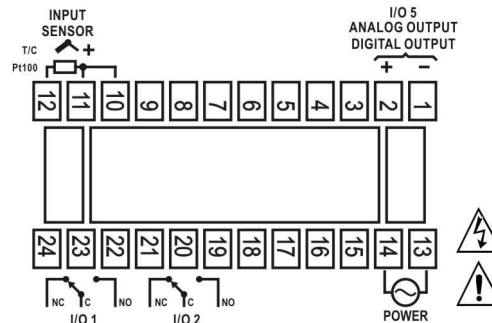

Figure 1 – Controller electrical connections

2.3 CONTROL OUTPUTS AND ALARM

There are THREE outputs for process control or alarm.

- O/I 1: - Relay output, SPDT 3 A / 250 Vac (3 A / 30 Vdc);
- O/I 2: - Relay output, SPDT 3 A / 250 Vac (3 A / 30 Vdc);
- O/I 5: - Output current 0-20 mA / 4-20 mA; 500 R max;
- Digital Pulse Output; 12 V / 25 mA;

The output features (control or alarm) are user-defined at the controller settings. The I/O output is able to provide a current signal of 0-20 mA or 4-20 mA and a voltage pulse digital signal with no changes in the controller hardware required.

Different outputs may be set up to perform the same function. The outputs are automatically turned off whenever the controller displays the message "Er I", which accounts for a device fault or disconnection.

3. SET UP AND OPERATION

The controller must be configured before use. The user must assign each parameter a condition presented as, for example, type of temperature sensor ("TYPE"), required work temperature ("SP"), temperature values for alarm triggering ("R ISP"), etc.

3.1 PARAMETERS ORGANIZATION

The controller parameters are organized in six levels (parameter sets):

Operation / Tuning / Program / Alarm / Output / Calibration

When the controller is turned on, the Operation level is displayed and remains activated during normal operation. The other levels can be accessed when changes are required in the controller set up.

To access the other levels, press together the keys **[P]** and **[◀]**.

When you reach the required level, which can be identified through the first parameter shown, use the key **[P]** to access the other parameters in this level. At the end of each level, the controller returns to the Operation level, showing the process temperature. When the keyboard is not activated for more than 20 seconds, the controller returns to the Operation level, showing the process temperature.

Using **[▲]** and **[▼]** the operator is allowed to change the value of each parameter shown.

Set up changes are saved in a protected memory and the controller will use them as soon as the user passes to the next parameter or in case no key is pressed within 20 seconds. This is not valid for the **run** parameter, whose setting changes are immediately taken by the controller.

3.2 OPERATION LEVEL

TEMPERATURE AND SP Set Point	TEMPERATURE AND SP DISPLAY: The upper display shows the current measured temperature. The lower display indicates the control SP value. If the measured temperature exceeds the sensor range limits or the input is open (broken sensor), the screen will display "- - -". In hardware faults, the screen will display "Er I"
Pr n	PROGRAM EXECUTION: Determines the immediate execution of the ramp and soak program elaborated at the program level. no – does not run the program; YES – runs the program created; When the control is enabled (run= YES) the selected program will run immediately.
run	RUN: In this screen it is possible to enable or disable the controller action, turning on or off the alarm control outputs. 0 – Does not enable outputs; 1 – Disable outputs;

3.3 TUNING LEVEL

Rtun	AUTO-TUNE: Enables the auto tune of PID parameters. 0 – Auto-tune disabled; 1 – Auto-tune enabled;
Pb	PROPORTIONAL BAND: P parameter of the PID control mode. Expressed as a percentage of the maximum range of the type of sensor used. Adjustable from 0 to 500 %. To use the control mode ON/OFF , set zero (0).
Ir	INTEGRAL RATE: Value of the integral parameter (I) of the PID control mode. Expressed as repetitions per minute. Adjustable from 0.00 to 55.20 repetitions per minute. It is not displayed when the ON/OFF control is selected (Pb=0).
dt	DERIVATIVE TIME: Value of the derivative parameter (D) of the PID control mode, in seconds. Adjustable from 0 to 250 s. It is not displayed when the ON/OFF control is selected (Pb=0).
Ct	PWM CYCLE TIME Value in seconds of the PWM of the control output: Adjustable from 0.0 to 99.9 seconds. In processes that use power contactors, this value must be higher than 10s. In process with solid state relays, it is possible to use lower values. It is not displayed if the ON/OFF control is selected (Pb=0).
HYST	CONTROL HYSTERESIS It is the ON/OFF control hysteresis (programmed in a temperature unit). Used only when the controller is set to ON/OFF control (Pb=0).
Act	CONTROL ACTION rE – Reverse Action usually used for heating. d Ir – Direct Action usually used for cooling.
R ISP R2SP	Alarm 1 and 2 setpoints: Temperature values that trigger alarm 1 and 2.

3.4 PROGRAM LEVEL

Ptol	PROGRAM TOLERANCE: Maximum deviation between the program PV and SP. If it is exceeded, the program is aborted (stops counting the time) until the deviation falls within the tolerance range. Set zero to disable this function.
PSP0 PSP7	PROGRAM SPs, 0 to 7 Set of 8 SP values that define the ramp and soak program profile.
Pt 1 Pt 7	PROGRAM SEGMENTS TIME, 1 to 7 Defines time, in minutes, of each program segment.
Loop	PROGRAM LOOP: Option for automatic restart of the ramp and soak program. YES – Restart the program automatically. no – Does not restart the program automatically.

3.5 CONFIGURATION LEVEL

FuR 1 FuR2	FUNCTION OF ALARM 1 and 2 Selects the function for Alarms. See Table 2 for a description of functions and their code, which will be programmed in this screen. oFF, iErr, Lo, HI, dIFL, dIFH, dIF
bLR 1 bLR2	INITIAL ALARM BLOCKING Initial alarm blocking function for alarms 1 to 4. YES – enables the initial blocking no – disables the initial blocking
HYR 1 HYR2	ALARM HYSTERESIS: Defines the difference between the temperature value that enables and the one that disables the alarm.

3.6 CONFIGURATION LEVEL

tYPE	INPUT TYPE: Selection of the type of temperature sensor that will be used. See Table 1. This must be the first parameter to be set up. 0 - J Thermocouple; 4 - R Thermocouple; 1 - K Thermocouple; 5 - S Thermocouple; 2 - T Thermocouple; 6 - Pt100 with a resolution of 0.1 °; 3 - N Thermocouple; 7 - Pt100 with a resolution of 1 °;
unIt	TEMPERATURE UNIT: Selects the indication in degrees Celsius or Fahrenheit. 0 - degrees Celsius (°C); 1 - degrees Fahrenheit (°F);
oFFS	OFFSET FOR THE PV: Parameter for correction of the indicated temperature. The adjusted value is added to the measured value before indication. Normally set to zero. Adjustable from -400 to +400.
SPLL	SET POINT LOW LIMIT: Determines the minimum possible value for adjustments carried out in SP and PV related parameters. Value in degrees, adjustable within the ranges of the programmed sensor.
SPHL	SET POINT HIGH LIMIT: Determines the maximum possible value for adjustments carried out in SP and PV related parameters. Value in degrees, adjustable within the ranges of the programmed sensor.

3.7 OUTPUT LEVEL

Io 1 Io 2	I/O FUNCTION 1 AND 2: Selection of the function used in the I/O output 1 and output 2. Available options are: 0 – not used; 1 – Alarm 1; 2 – Alarm 2; 3 – Control Pulse PWM
----------------------	----------------------------------------------------------------------------------------------------------------------------------------------------------------------------------------------------------------------------

Io 5	I/O FUNCTION 5: Selection of the function used in the I/O output 5. Available options are: 0 – not used; 1 – Alarm 1; 2 – Alarm 2; 3 – Control Pulse PWM 7 – Control with 0-20 mA 8 – Control with 4-20 mA
FFunc	F KEY FUNCTION – It allows to define a function for the F key. Functions available are: 0 – No t used / No function assigned; 4 – Commands control and alarm outputs (function of the run parameter); 5 – Interrupts the execution of the ramp and soak program; 6 – Triggers the execution of the ramp and soak program;

3.8 CALIBRATION LEVEL

ATTENTION

The following parameters are used in the calibration of the temperature readings. To change them, proper knowledge and devices are required.

inLC	OFFSET CALIBRATION OF THE SELECTED SENSOR. Allows for changing the amplifier offset of the sensor signal. The value shown is the calibrated temperature. The offset value can not be visualized. The offset adjustment requires the application of a low and known temperature value in the sensor, or the simulation.
inHC	GAIN CALIBRATION OF THE SELECTED SENSOR. Allows for changing the amplifier gain of the sensor signal. The value shown is the calibrated temperature. The gain value can not be visualized. The gain adjustment requires the application of a high and known temperature value in the sensor, or the simulation.
ouLL	OUTPUT OFFSET CALIBRATION: Value for the offset (zero) calibration of the analog current output.
ouHC	OUTPUT GAIN CALIBRATION: Value for the gain (span) calibration of the analog current output.
[] L	OFFSET CALIBRATION OF THE COLD JUNCTION: Value for the offset calibration of the cold junction temperature.

3.9 SET UP PROTECTION

It is possible to prevent settings to be changed after the final set up so that undesirable alterations are performed. It is possible to visualize the parameters, but they cannot be changed. Protection is achieved with the combination of some key strokes and an internal key.

Press **▲** and **◀** together for 3 seconds, at the level you want to protect.

To unprotect a cycle, press **▼** and **◀** together for 3 seconds.

The displays will flash briefly to confirm the protect and unprotect actions.

Inside the controller, the PROT key completes the protection function. In the **OFF** position, the user is allowed to protect and unprotect levels. In the **ON** position it is not possible to carry out changes: if the levels are protected, it is not possible to remove protection; if they are not protected, it is not possible to accomplish changes.

4. TROUBLESHOOTING

Connection mistakes and configuration errors represent great part of problems presented in the controller operation. A final review can avoid waste of time and other damages. Some messages are aimed at helping the user identify problems.

---: The sensor temperature reading is below the min. temperature defined.

---: The sensor temperature reading is above the max. temperature defined.

Er 1: Controller fault or Sensor error, examples: Opened thermocouple, opened, short-circuited or badly connected Pt100.

If the message "**Er 1**" persists after the installation is reviewed, contact the manufacturer and inform of device serial number.

5. ALARM FUNCTION DESCRIPTION

Minimum and maximum alarms are used to signal extreme temperature values. Such extreme values are defined in the "**R1SP**" and "**R2SP**". Differential alarms are used to signal deviations between the temperature and the control setpoint (**SP**). User-defined values in the "**R1SP**" and "**R2SP**" parameters represent the values of such deviations.

The initial blocking prevents the alarm from being triggered when the controller is turned on until the temperature reaches the SP value for the first time.

The error alarm in the sensor signals sensor faults.

Table 2 shows the operation of each alarm function, using alarm 1 as an example, and presents its identification code in the "**RIFu**" and "**R2Fu**" parameters.

TYPE	PROMPT	ACTION
Disabled	oFF	Alarm disabled
Open Sensor (input Error)	iErr	Triggered when the sensor is broken
Minimum value (Low)	Lo	
Maximum value (High)	HI	
Minimum differential (Differential Low)	dIFLo	
Maximum differential (Differential High)	dIFHI	
Out of range differential (Differential Out)	dIFou	
Differential within range (Differential In)	dIFIn	

Table 2 – Alarm functions and identification codes

6. PID PARAMETERS AUTO-TUNE

One of the major doubts users have is to know which values to adopt in PID parameters for a more effective control of the process. The Auto-tune (**Rtun**) is the controller resource that determines such values automatically.

When the Auto-tune is enabled, the controller will control the process temperature and identify its characteristics, calculating the best values for the PID parameters. During auto-tune the process is controlled in the **ON/OFF** mode in the programmed value of the setpoint. Depending on the process features, great temperature oscillations may occur, above and below the SP value. The user must check if the process supports such oscillations. Auto-tune can take several minutes to conclude in some processes.

In the controller front panel, the signal **TUNE** lights when auto-tuning is being performed. At the end of the process, the signal disappears. For other SP values, other PID parameters may be required. The recommended procedure is the following:

- Program SP as a value close to the value in which the process will operate after tuned.
- Enable the auto-tune in the "**Rtun**" prompt by selecting **t**
- Program **I** in the "**run**" prompt.

If auto-tune does not result a satisfactory control, **Table 3** shows actions that will adjust the process behavior.

PARAMETER	PROBLEM	SOLUTION
Proportional band	Slow response	Decrease
	Large oscillation	Increase
Integration rate	Slow response	Increase
	Large oscillation	Decrease
Derivative time	Slow response or instability	Decrease
	Large oscillation	Increase

Table 3 – Orientation for the manual adjustment of the PID parameters