

INTRODUCTION

N322RHT is a relative humidity and temperature electronic controller. It includes two relay-type control outlets that may be independently configured for functioning as a control or alarm.

The equipment includes humidity and temperature sensors. They are protected by a polyamide capsule and have 3-meter long cables.

The display shows, alternately, the temperature and humidity. Time between those indications is configurable by the user.

CE (European Union) and UL (United States and Canada) certifications compliant.



FEATURES & SPECIFICATIONS

- One control outlet (Output1) with a SPDT relay, 1HP (16A resistive) /250Vac and another control outlet (Output2) with a SPST relay, 3A (5A resistive)/250 Vac
 - 3½-digit LED Display
 - Sensor offset adjustment
 - Adjustable hystereses
 - Configurable setpoint minimum and maximum limits
 - Program retention during power failures
 - Configurable password equipment protection
 - Silicone keys with excellent durability
 - Front-panel with IP65 protection
 - Humidity and temperature measuring ranges (see figure):
 - RH: 0 to 100% of relative humidity
 - T: -20 to 100 °C
 - Measurement resolution:
 - RH: 1% in the whole range
 - T: 0.1 °C from -19.9 to 100.0 °C
 - Accuracy: See figure
 - Power supply: 100 to 240Vac /dc ±10%
 - Frequency: 50~60 Hz
 - Consumption: 5 VA
 - Dimensions:
 - Humidistat: 75 x 33 x 75 mm
 - Sensor: 125 x 13.7 mm (length x diameter)
 - Sensor cable: 3 meters
 - Panel cutout: 70 x 29 mm
 - Weight: 120 g
 - Operational temperature: 0 to 40 °C
 - Storage temperature: -20 to 60 °C
- OPTIONAL**
- RS485 interface with Modbus RTU protocol
 - Power supply: 12 to 24Vac/dc
- APPLICATION**
- Flowers, fruits, and vegetables storage rooms; air conditioning; data centers.

ELECTRICAL CONNECTIONS

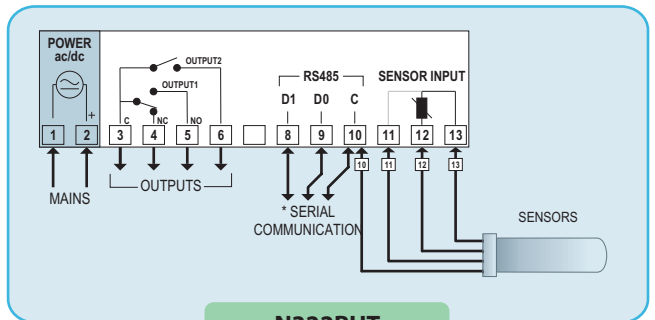

N322RHT

Accuracy of measuring humidity and temperature

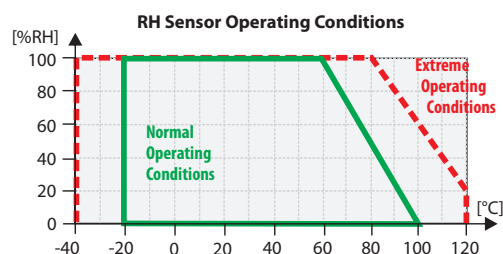
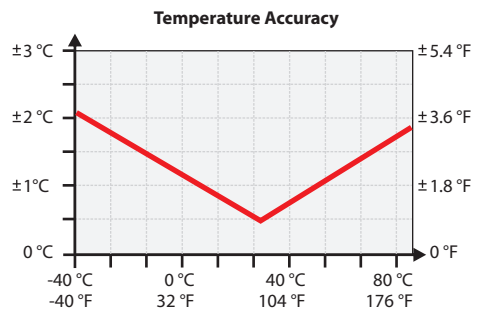
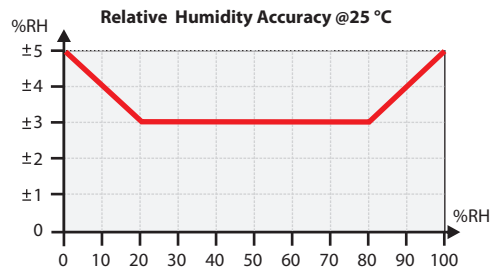

HOW TO SPECIFY

MODEL: **N322 - A - B - C**, where:

A: Sensor:	RHT
B: Communication:	Blank or 485 (RS485, RTU Modbus Protocol)
C: Power supply:	Blank (100-240 Vac/dc) or 24V (24 Vac/dc)