

INTRODUCTION

Logbox-RHT and LogBox-RHT-LCD are dual channel data loggers with built-in temperature and relative humidity sensors. They use a high quality industrial grade humidity sensor for accurate and reliable operation in applications such as transportation, food and goods storage, process auditing, pharmaceutical, HVAC and others.

They can be easily programmed and set via a handy infrared **IR-LINK 3** interface connected to a USB port under Windows® software or with a PalmOS compatible PDA IrDA interface. **LogChart II** software allows for logger configuration, recorded data retrieval, plotting, historical analysis and it exports data to spread sheets.

In the **LogBox-RHT-LCD** the temperature and humidity values are shown in the digital display. You can also check on the display the Minimum and maximum recorded values.



CONFIGURATION

- **LogChart II** software allows for logger configuration, recorded data retrieval, plotting and historical analysis and exports data to spread sheets.
- Infrared communication to a PC is achieved by using the interface **IrLink 3** connected to a USB port (RS232 is optional).
- Configuration, data retrieval and analysis can be done also by using a convenient Palm OS compatible PDA through its **IrDA** interface. This reduces cost and dramatically increases portability.
- Data downloaded from multiple **LogBox** units to a Palm can be later transferred and synchronized to a PC by means of the native Palm sync tool.
- Once the data are transferred to a PC they can then be better visualized and exported by the **LogChart II** software.

SPECIFICATIONS

- Temperature measurement:
 - Range: -40 to 80°C. Resolution: 0.1°C;
 - Response time: up to 30 s in fairly still air.
- Humidity measurement:
 - RH Range: 0 to 100 %RH. Resolution: 0.1 %RH;
 - Dew point range: -40° to 100 °C. Resolution 0.1 °C;
 - Response time: 8s in fairly still air, from 20 to 80 %RH.
- Accuracy: See figure.
- Memory for 32,000 recordings in one channel or 16,000 recordings for each channel.
- Recording interval: programmable from 1 s to 18 hours.
- Logger start: immediately, outset by the device's button, by date/hour or by a programmed setpoint.
- Logger stop: at full memory; at some specified date and hour, number of samples or never stop (circular memory).
- Infrared communication range: 50 cm, 30° angle.
- Internal replaceable lithium cell (3.6V ½ AA).
- Estimated battery life: up to 200 days with one weekly download and 5 minutes measuring interval. Battery life depends heavily on data retrieval frequency.
- Configuration and data retrieval software for Windows 98, XP, 2000, Vista and PalmOS.
- Operating temperature: -40°C to 70°C.
- Enclosure: IP65 (electronics), IP40 (sensor probe), flame retardant, ABS+PC.
- Dimensions: 70 x 60 x 35 mm.

Accuracy and Operational Limits

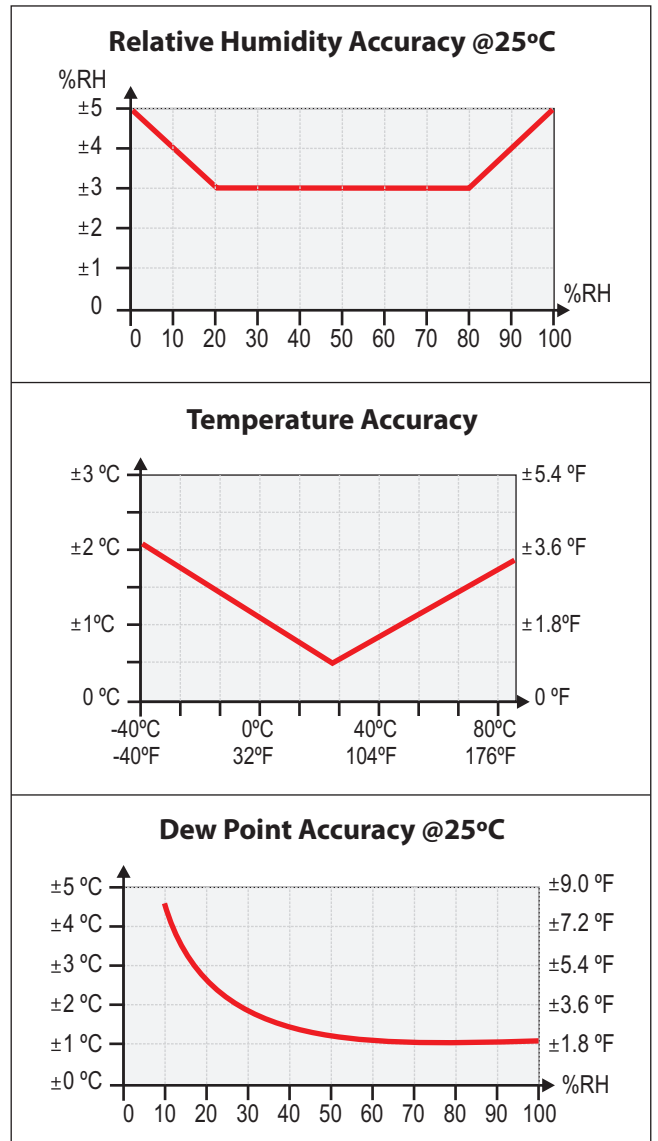

The RH sensor used in the equipment may be damaged or descalibrated when exposed to contaminated atmospheres or chemical agents. Hydrochloric, nitrous or sulphuric acid or ammonia in high concentrations may damage the sensor. Acetone, ethanol and propylene glycol may cause reversible measuring errors.

DATA ANALYSIS

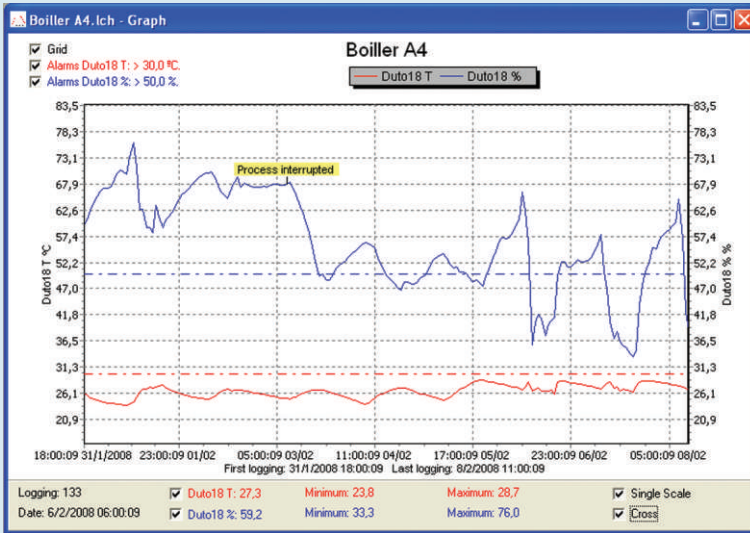

GRAPH

Parameters Configuration

Title: Boiler A4

General Information
Model: LogBox-RHT-LCD
Serial Number: 8888
Data Logger Date/Time: 8/4/2008 11:46:44
Actual Date/Time: 8/4/2008 11:41:02

Acquisitions Channels

Channel 1
Tag: Duto18 T
Input: Temperature
Unit: °C
Alarm: [PC]
Offset: 0,0
Value: Average

Channel 2
Tag: Duto18 %
Input: Humidity
Unit: %
Offset: 0,0
Value: Average

Loggings Table

Loggings No	Time	Date	Duto18 T (°C)	Duto18 % (H)
00001	18:00:09	31/1/2008	26,1	59,9
00002	19:00:09	31/1/2008	25,7	60,8
00003	20:00:09	31/1/2008	25,2	62,6
00004	21:00:09	31/1/2008	24,9	64,2
00005	22:00:09	31/1/2008	24,7	65,4
00006	23:00:09	31/1/2008	24,5	66,4
00007	00:00:09	1/2/2008	24,4	67,0
00008	01:00:09	1/2/2008	24,2	67,1
00009	02:00:09	1/2/2008	24,2	67,2
00010	03:00:09	1/2/2008	24,1	68,2
00011	04:00:09	1/2/2008	24,0	68,6
00012	05:00:09	1/2/2008	23,9	70,6
00013	06:00:09	1/2/2008	23,8	70,3
00014	07:00:09	1/2/2008	23,8	69,9
00015	08:00:09	1/2/2008	23,9	73,3
00016	09:00:09	1/2/2008	24,4	76,0
00017	10:00:09	1/2/2008	25,3	71,3
00018	11:00:09	1/2/2008	26,3	69,8
00019	12:00:09	1/2/2008	26,9	62,7
00020	13:00:09	1/2/2008	27,0	59,2
00021	14:00:09	1/2/2008	27,3	59,1
00022	15:00:09	1/2/2008	27,2	59,1
00023	16:00:09	1/2/2008	27,3	63,7
00024	17:00:09	1/2/2008	27,6	61,4
00025	18:00:09	1/2/2008	27,7	59,2
00026	19:00:09	1/2/2008	27,1	60,7
00027	20:00:09	1/2/2008	26,9	61,4
00028	21:00:09	1/2/2008	26,6	62,1
00029	22:00:09	1/2/2008	26,3	63,6
00030	23:00:09	1/2/2008	26,1	64,9
00031	00:00:09	2/2/2008	25,9	65,9
00032	01:00:09	2/2/2008	25,8	66,3

CONFIGURATION

TABLE

MODELS

LogBox-RHT

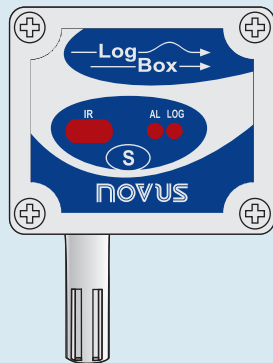

LogBox-RHT-LCD

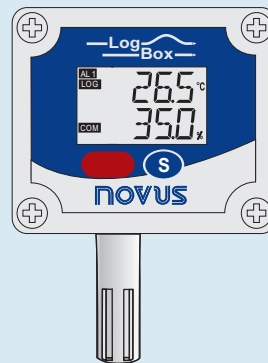

DIMENSION

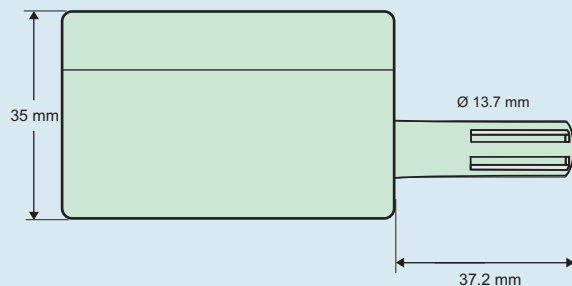
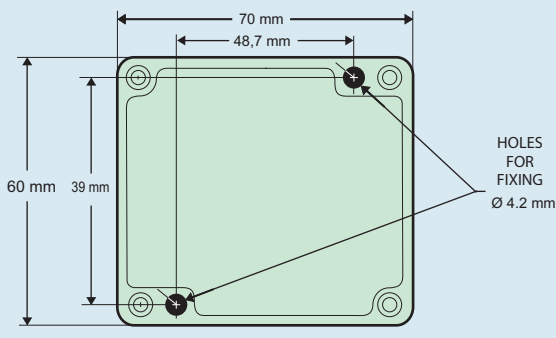

DATA ACQUISITION, LOGGING & SUPERVISORY SYSTEMS