

# SPECIFICATION

## PRIMUS Clinical – Large Size Sterilizers

*These sterilizers are designed for all Clinical applications including surgery, central sterile supply. They are pit-mounted, allowing the optional floor carts to roll directly into the chamber. PRIMUS sterilizers are designed, developed and manufactured in the USA according to Quality Management System which are in compliance with ISO 9001:2000 and FDA's Good Manufacturing Practice for Medical Devices: General (GMP) regulation (21CFR Part 820).*



Two 26" x 63" Pit Mounted Units

### STERILIZER DESIGN

The pressure vessel is the heart of any sterilizer. PRIMUS offers simple, straight forward, design. All PRIMUS pressure vessels are constructed of solid stainless steel and are fabricated by PRIMUS in our quality controlled, ASME facility. The interior chamber surface is polished to a mirror finish of  $<10\mu$  in. Ra. The brilliant Pri-Mirror<sup>®</sup> reflective chamber finish sets the highest standard for cleanliness and offers easy spill clean-up and resistance to staining and degradation.

PRIMUS rectangular chambers eliminate the wasted space and high utility cost common to old-style cylindrical or elliptical chambers and jackets. This provides savings in operating cost and service.

All large sizes of PRIMUS sterilizers have pneumatically powered horizontal operating doors, designed to be efficient, reliable and inherently safe. To close the door, depress and hold the door button, if button is released door opens. An added safety feature, the doors stop automatically if an obstacle is encountered.

Pit-mounted sterilizers with matching floor loading carts are guided into the chamber by floor tracks which match cart casters. Pass-through models are available

### STERILIZER CYCLES

All PRIMUS steam sterilizers include Gravity, Vacuum and Liquid cycle settings. A Test/Vac cycle is provided for utilizing Bowie-Dick<sup>™</sup> tests.

For surgical packs, select one of the vacuum cycles. For the sterilization of liquids in open or vented containers, select a liquids cycle.

The time-tested and reliable PRIMUS PSS500 Microcomputer Control is an industrial microprocessor providing accuracy and automation for all customer requirements. This simple, versatile, control has become the first choice for both sterilizer users and service technicians.



PRIMUS Sterilizer Co., Inc. • 117 South 25<sup>th</sup> Street • Omaha, NE 68131

DATA SHEET

## PURCHASING SPECIFICATION DATA SHEET

# SPECIFICATION DATA SHEET

### GENERAL *(Options italicized)*

All models shall include Vacuum, Gravity and Liquids cycles. *A Low Temperature Flowing Steam option provides flowing steam at low temperatures for Research laboratories for specific applications.*

### VESSEL MATERIAL AND CONSTRUCTION

The sterilizer will have a double-wall design providing for a fully jacketed pressure vessel. The chamber cross section will be rectangular with width and height dimensions to include:

J - 26" x 63" x 48"  
K - 26" x 63" x 76"

The vessel material will be non-laminated solid stainless steel plate/sheet. The chamber, head-ring and door material will be 316L stainless steel with an interior Pri-Mirror® finish of <10µ in. Ra.

### DESIGN and MANUFACTURING APPROVALS

The vessel will be designed and constructed to ASME code Section VIII Division I and pressure rated for 45 PSIG and full vacuum. ASME Code Stamp and U-1 form will bear the name of PRIMUS as the specified US manufacturer.

The sterilizer will be manufactured according to Quality Management Systems which are in compliance with ISO 9001:2000, will be UL listed and in conformance to CSA requirements.

### DOOR CONSTRUCTION

A pneumatically operated horizontally sliding door will be operable from the touchpad push button. To close door, depress/hold door button. If door button is released while closing, door reverses direction and opens. In the open position, the insulated door will be secured behind a panel preventing the operator from contact with hot surfaces. An interlock will prevent cycle start unless the door is fully closed and secured.

### GENERAL CONSTRUCTION

The vessel shall be insulated with 1" semi-rigid high temperature fiberglass board/blanket overlaid with formed aluminum paneling and mounted in a structural steel frame. The frame shall be enamel coated and fitted with adjustable legs on self-centering floor pads. The fascia and side panels will be 16-gauge, type 304 stainless-steel, removable for easy service access.

### WATER CONSERVATION

To conserve water and assure effluent exhausted to drain is 140°F or below, PRIMUS provides quench water on demand for exhaust effluent.

### EQUIPMENT WARRANTY

Sterilizer pressure vessels manufactured by PRIMUS are warranted against defects in workmanship and materials under normal use and operation for fifteen years where the sterilizer is continually maintained under PRIMUS service contract.

### SERVICE and EQUIPMENT ACCESS

Standard service access, when facing the unit will be from left side and top. Wiring shall be laid side-by-side and mechanically secured flat against metal insulations cover. All wiring will be clearly labeled and readily visible for visual tracing. Piping components will be threaded rigid brass and flared copper fittings, positioned with sufficient space for removal and replacement without disassembly of the entire piping assembly. Wiring and piping components will be nonproprietary, industrial grade available through Authorized Service Agencies, local supply house, or direct from PRIMUS.

### STEAM SOURCE

Steam will be from an in-house steam source in the quantity and quality specified. *An optional electric boiler may be specified. Contact PRIMUS for specific boiler information*

### CONTROLS

A PSS500 microcomputer will offer a selection of 8 (eight) separate programs for the sterilization of wrapped goods, hard-goods, liquids and test cycles. An automatic Vacuum Leak Test cycle is provided to ensure the seal integrity of the vessel and piping. Cycle parameters may be set by the user and are adaptable to a wide range of products. Alarms are annunciated, displayed and recorded throughout the cycle. A side-mounted control panel and a thermal printer dot-matrix technology, and 32 characters per line printing is provided. A second copy of the sterilization cycle report will be available at the end of the run.



*Standard Control Panel /Printer Arrangement*

**HVAC DATA** Heat loss, at ambient of 70° F.

	MODEL	KBTU'S/HR
<b>SINGLE DOOR:</b> Through one wall, at fascia	J	5
	K	5
<b>SINGLE DOOR:</b> Through one wall, servicearea	J	11.8
	K	12
<b>SINGLE DOOR:</b> Free standing, cabinet total	J	16
	K	16

	MODEL	KBTU'S/HR
<b>DOUBLE DOOR:</b> Through one wall, at fascia	J	5
	K	5
<b>DOUBLE DOOR:</b> Through one wall, service area	J	16
	K	16
<b>DOUBLE DOOR:</b> Through two walls, at each fascia	J	5
	K	5
<b>DOUBLE DOOR:</b> Through two walls service area	J	10
	K	10

**DIMENSIONS, CUBAGE & WEIGHTS**

Model Sterilizer Size inches/millimeters	J 26" x 63" x 48" 660.4 x 1600.2 x 1219.2	K 26" x 63" x 76" 660.4 x 1600.2 x 1930.4
Overall Dimensions, of Frame	41 x 90 x 60 1041.4 x 2286 x 1524	41 x 90 x 88 1041.4 x 2286 x 2235.2
Weight, Single Door	<b>CONTACT PRIMUS FOR WEIGHTS</b>	
Weight, Double Door		
Crated Weight	<b>VAN DELIVERY ONLY</b>	
Crated Dimensions	42 x 92 x 61 1066.8 x 2336.8 x 1549.4	42 x 92 x 89 1066.8 x 2336.8 x 2260.6
Crated Cube	137 cu ft / 4m <sup>3</sup>	200 cu ft / 6m <sup>3</sup>
Loading Equipment (Floor Carts)	152 lb/ 69 kg	240 lb/ 109kg
Boiler	785 lb/ 356 kg	790 lb/ 359kg



# PRIMUS Clinical - Large Sterilizers

## SINGLE DOOR

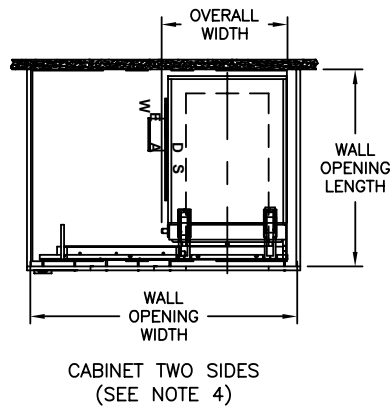
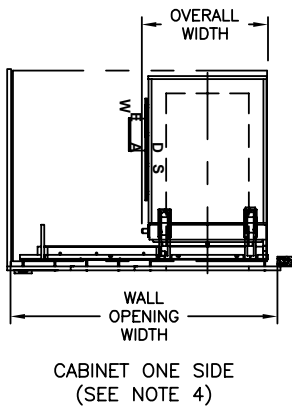
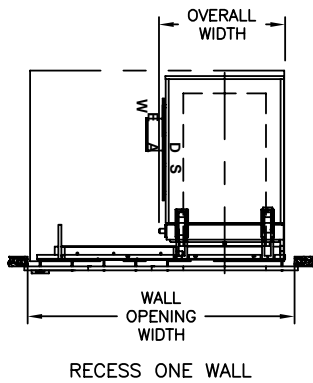
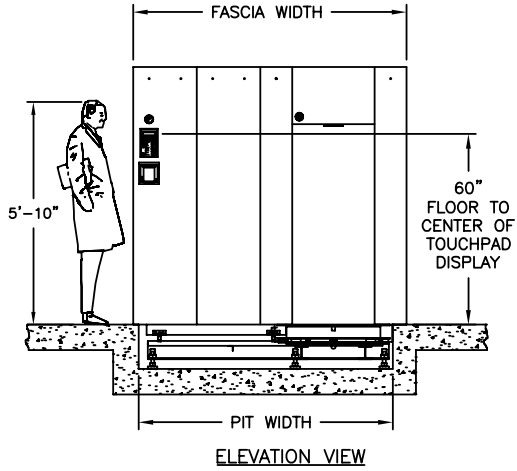
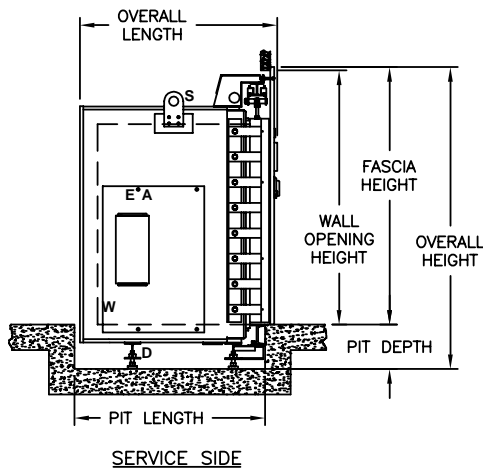

**PLAN VIEWS**

## VOLUME/DIMENSIONS CHART

Refer to General Arrangement drawings for details and final connection point to utility services.  
(S-Steam, W-Water, D-Drain, E-Electrical)

MODEL	J	K
<b>Chamber Size (w x h x l) inches/millimeters</b>	<b>26 x 63 x 48 660 x 1600 x 1219</b>	<b>26 x 63 x 76 660 x 1600 x 1930</b>
<b>Chamber Capacity</b>	<b>45.5 ft<sup>3</sup> / 1.29 m<sup>3</sup></b>	<b>72.0 ft<sup>3</sup> / 2.04 m<sup>3</sup></b>
Overall Width	40.25 / 1022.35	40.25 / 1022.35
Overall Height <sup>1</sup>	109.00 / 2768.6	109.00 / 2768.6
Overall Length (SD) <sup>2</sup>	64.00 / 1625.6	92.00 / 2336.8
Wall Opening Width	84.00 / 2133.6	84.00 / 2133.6
Wall Opening Height	93.00 / 2362.2	93.00 / 2362.2
Wall Opening Length <sup>3</sup>	62.25 / 1581.15	90.25 / 2292.35
Fascia Width	86.00 / 2184.4	86.00 / 2184.4
Fascia Height	94.00 / 2387.6	94.00 / 2387.6

- Fascia extends 1" beyond wall opening on each side overlapping the wall and sealing the opening.
- Allow minimum 2" clearance at rear of recessed unit only. Cabinet side models have rear clearance built in.
- Contact PRIMUS for alternative wall opening.
- Standard left side service/equipment access show. Optional right side access is available.



# PRIMUS Clinical - Large Sterilizers

## DOUBLE DOOR

SPECIFICATION DATA SHEET

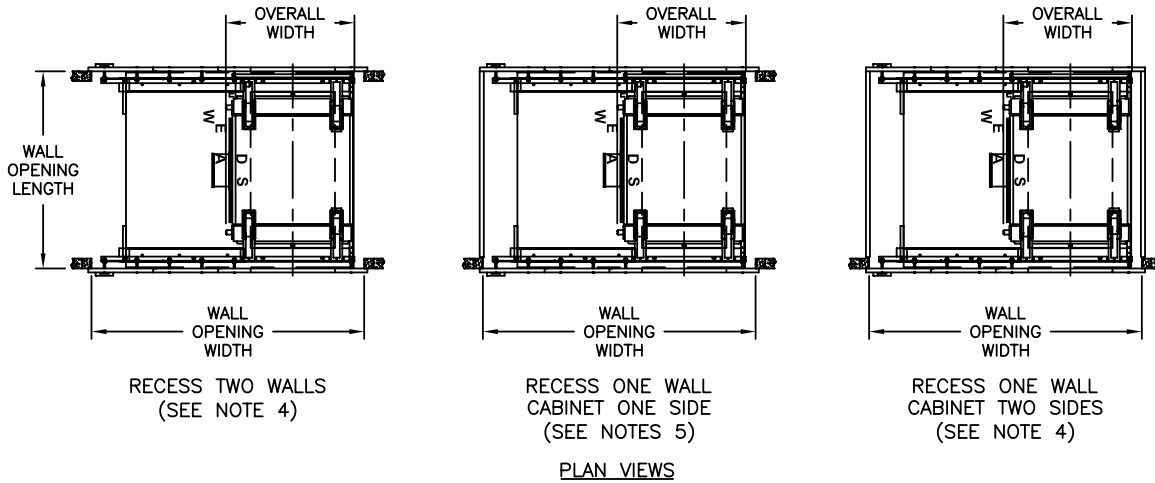
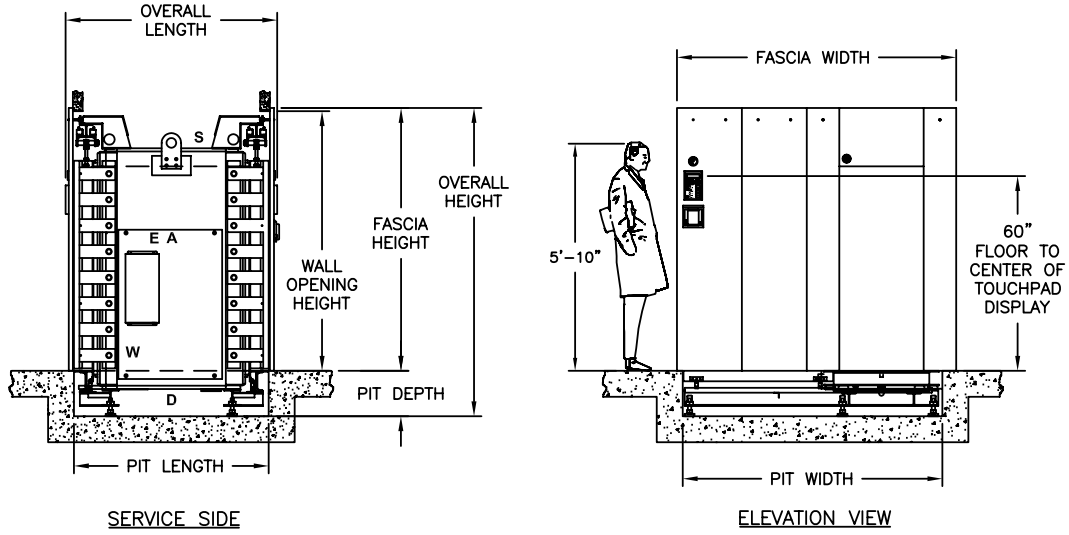

### VOLUME/DIMENSIONS CHART

Refer to General Arrangement drawings for details and final connection point to utility services.  
(S-Steam, W-Water, D-Drain, E-Electrical)

MODEL	J	K
<b>Chamber Size (w x h x l) inches/millimeters</b>	<b>26 x 63 x 48 660 x 1600 x 1219</b>	<b>26 x 63 x 76 660 x 1600 x 1930</b>
<b>Chamber Capacity</b>	<b>45.5 ft<sup>3</sup> / 1.29 m<sup>3</sup></b>	<b>72.0 ft<sup>3</sup> / 2.04 m<sup>3</sup></b>
Overall Width	40.25 / 1022.35	40.25 / 1022.35
Overall Height <sup>1</sup>	109.00 / 2768.6	109.00 / 2768.6
Overall Length (DD) <sup>2</sup>	70.13 / 1781.18	98.13 / 2492.5
Wall Opening Width <sup>3</sup>	84.00 / 2133.6	84.00 / 2133.6
Wall Opening Height	93.00 / 2362.2	93.00 / 2362.2
Wall Opening Length	62.44 / 1585.91	90.44 / 2297.11
Fascia Width	86.00 / 2184.4	86.00 / 2184.4
Fascia Height	94.00 / 2387.6	94.00 / 2387.6

1. Fascia extends 1" beyond wall opening on each side overlapping the wall and sealing the opening.
2. Allow minimum 2" clearance at rear of recessed unit only. Cabinet side models have rear clearance built in.
3. Contact PRIMUS for alternative wall opening.
4. Standard left side service/equipment access show. Optional right side access is available.



# PRIMUS Clinical - Large Sterilizers

## PIT INSTALLATION DETAILS

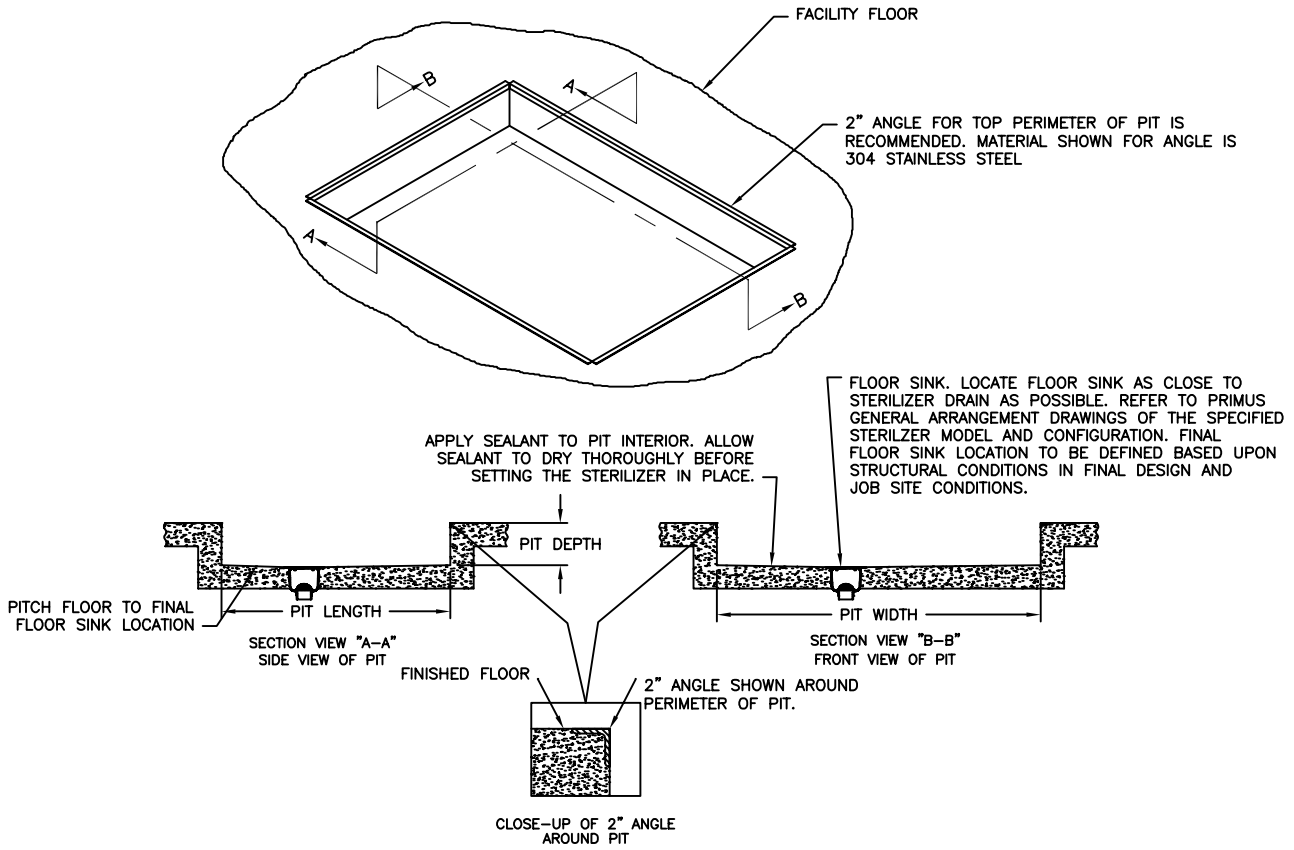

Drawing is general example of PRIMUS' pit installation. Refer to PRIMUS' General Arrangement (GA) drawings for exact dimensions and pit installation details. Prior to installing your PRIMUS sterilizer verify the pit dimensions are correct with the PRIMUS GA Drawings, ensure the pit is square, clean and sealed. Contact PRIMUS for further pit installation information.

## PIT DIMENSIONS CHART

MODEL	J	K
<b>Chamber Size (w x h x l) inches/millimeters</b>	<b>26 x 63 x 48 660 x 1600 x 1219</b>	<b>26 x 63 x 76 660 x 1600 x 1930</b>
<b>Chamber Capacity</b>	<b>45.5 ft<sup>3</sup> / 1.29 m<sup>3</sup></b>	<b>72.0 ft<sup>3</sup> / 2.04 m<sup>3</sup></b>
Pit Depth	14.00 / 355.6	14.00 / 355.6
Pit Length (SD)	60.00 / 1524.0	88.00 / 2235.2
Pit Length (DD)	58.50 / 1485.9	86.50 / 2197.1
Pit Width	80.00 / 2032	80.00 / 2032

### ARCHITECTURAL NOTES:

1. Allow sufficient space for traps, shut-off's, filters and other utility supply components.
2. Utility (service disconnects) shall be provided and installed "By Others".
3. Provide maximum mechanical and service access space, a minimum of 24", additional space required when boiler specified. See General Arrangement drawing for placement of ancillary equipment and service access.
4. Some options affect utility services and overall dimensions.
5. The Manufacturer's Equipment Warranty does not cover failure due to improper utility provisions.
6. Drawings not to scale.
7. Wall thickness must be provided on double door models recessed through 1 wall, with cabinet sides.

### STERILIZER UTILITY SERVICES

Stub-in utility services within 6"-0" of final connection to sterilizer. Optimum sterilizer performance requires the specified utilities.

Model	NPT	LBS/HR (KG / HR)	NPT	GPM (MAX) (Liter)	NPT (Discharge Pipe Size)	NPT
J	1"	364.0 (165.1)	3/4"	14 (53)	1"	1/4"
K	1"	480.0 (217.72)	1"	25 (95)	1 1/4"	1/4"

Utility Service	Requirements
<b>Steam</b> Building Steam Supply	<ul style="list-style-type: none"> <li>• <b>Pipe Size:</b> See below</li> <li>• <b>Quality:</b> Condensate free 97% to 100% saturated vapor (suitably trapped to ensure dry steam and filtered to remove particulates)</li> <li>• <b>Pressure:</b> 50-80 PSIG Dynamic</li> </ul>
<b>WATER</b> Cold Water Supply	<ul style="list-style-type: none"> <li>• <b>Pipe Size:</b> See Below</li> <li>• <b>Temperature:</b> &lt; 70° F</li> <li>• <b>Pressure:</b> 50-70 PSIG Dynamic</li> </ul>
<b>DRAIN</b> Building Drain System	<ul style="list-style-type: none"> <li>• Minimum 2"</li> <li>• <b>Location:</b> Locate floor sink directly under sterilizer</li> </ul> <p><b>Note:</b></p> <ol style="list-style-type: none"> <li>1.) Exhaust discharge is cooled to &lt; 140°F</li> <li>2.) 12" x 12" x 8" floor sink is recommended by PRIMUS</li> </ol>
<b>Air</b> Instrument Air	<ul style="list-style-type: none"> <li>• <b>Connection:</b> See Below</li> <li>• <b>Quality:</b> Dry and oil free</li> <li>• <b>Pressure:</b> 60-80 PSI Dynamic</li> </ul>
<b>ELECTRICAL</b> Building Steam Supply	<ul style="list-style-type: none"> <li>• <b>Volts:</b> 110</li> <li>• <b>Phase:</b> Single</li> <li>• <b>Amps:</b> 10</li> </ul> <p><b>Note:</b> Provide <b>dedicated</b> circuit to sterilizer controls. If optional boiler is specified, do not share this service.</p>

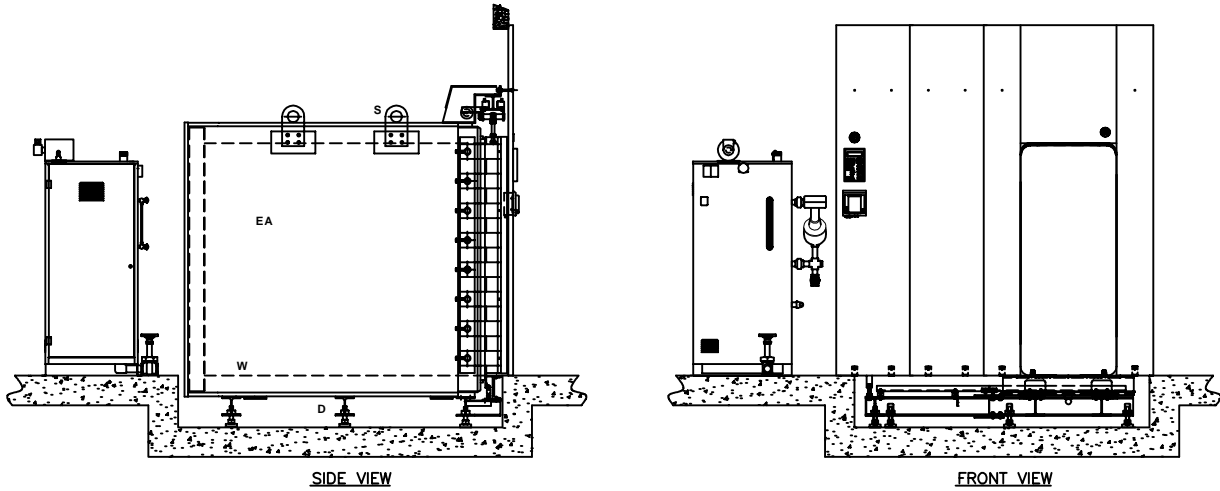

### ELECTRIC BOILERS

MODEL		J	K
Chamber Size (w x h x l) inches/millimeters		26 x 63 x 48 660.4 x 1600 x 1219	26 x 63 x 76 660.4 x 1600 x 1930
Boiler Size	KW/Hr.	136.0	180.0
Boiler Steam Output	lbs./Hr	410.0	542.0
Integral	Model	N/A	N/A
Stand Alone	Model	EB-J	EB-K
V.A.C. 208, 3 Ph	Amperes	378	N/A
V.A.C.240, 3 Ph	Amperes	328	434
V.A.C. 480, 3 Ph	Amperes	164	217
V.A.C. 110, 60 hz. <sup>1</sup>	Amperes	10	10

Use the following pages to custom design your sterilizer by checking the boxes of the configuration and options required for your project. Transfer all items checked to the Specification Worksheet (Page 12) and fax to PRIMUS Sales Department or to your local Sales Representative for a quotation. If you do not find an option or size listed to meet your requirements, please contact our Project Manager for additional information and assistance.

**Model Number Notation**

	SD = Single Door	Two models/sizes are offered:
	DD = Double Door	J - 26" x 63" x 48"
	↓	K - 26" x 63" x 76"
PSS5-__-M__-__-__		
↑     ↑		
J    S = House Steam		
K    E = Electric Boiler		

*A detailed formatted specification, suitable for inclusion in formal contract documents, is available on request.*

**Note:** Use the above format to determine PRIMUS Model number and insert below and on Page 12, Specification Worksheet.

PRIMUS Clinical Steam Pressure Sterilizer, Model Number PSS5\_\_\_\_\_.

### SELECT CONFIGURATION

**Door**

- DAR - Single Door (Right)
- DAL - Single Door (Left)
- DBR - Double Door (Right)
- DBL - Double Door (Left)

**Recessed**

- CA - One Wall
- CB - Two Walls

**Steam Source**

- House Supply
- Electric Boiler<sup>1, 2, 3</sup>
  - EB1 - 208/3 phase
  - EB2 - 240/3 phase
  - EB3 - 480/3 phase
  - Other \_\_\_\_\_
- EB0<sup>4</sup>- Auto. Blowdown
- LWC<sup>3</sup> - Low Water Cutoff with Manual Reset

**Cabinet**

- CD - Panels Both Sides
- CCL - Left Side Panel
- CCR - Right Side Panel

**Service and Equipment Access**

- Left Side (Standard)
- Right Side

1. Electric boilers are available in Carbon Steel or Stainless Steel.
2. Contact PRIMUS for overall dimensions and utility connections.
3. All models are stand-alone
- 3 Required in CA, IA, MA, MD, NC, TX and WA
4. If Option LWC is required, "the automatic" feature is disabled. The boiler will need to be manually reset.

## CLINICAL LABORATORY CONFIGURATIONS

**Low Temperature Flowing Steam P14**

For media preparation, formula and similar uses. Pasteurization is accomplished with flowing steam. In addition to standard sterilizer temperature ranges, this option allows cycles to operate in the range of 168°F (76°C) to 220°F (104°C). Not intended for reprocessing reusable medical devices

**Control Cycle on Load Temperature C24**

Used to establish the most beneficial cycle temperature and exhaust rate parameters. Monitors and controls the load temperature and controls the start of sterilization. Which will establish parameters for liquid loads and for loads with complex load geometries and a difficult path for steam penetration.

## CONTROLS AND RELATED OPTIONS

*(Contact PRIMUS for details and performance specifications)*

**PSS500 Control C6**

PSS500 microcomputer with eight (8) cycles; seven (7) programmable and 1 preset Test cycle are standard. A vertical touchpad contains a Liquid Crystal Display (LCD) mounted on a side-mounted control panel with a thermal printer. Cycle progression is displayed by Light Emitting Diodes (LEDs) on the operator panel and printed, 32 characters per line printing. A second copy of the entire sterilization cycle printable at the end of the run.

**Impact Printer R1**

Replaces standard 32 column thermal head printer with a 24 column impact printer. Available on both control systems.

**Remote Record of Run Data C11**

Mount control panel in separate housing adjacent to or up to 100 feet away from the sterilizer.

Cycles may be programmed by the end user but any deviation from the factory preset values must be validated by the end-user.

FACTORY PRESET CYCLES				
Load Type	Cycle Number	Cycle Type	Sterilize Temp	Sterilize Time (min)
Double Wrapped Instruments 16lbs each tray	1	Vacuum	273°F (134°C)	15
Unwrapped Nonporous Single Instrument	2	Vacuum	273°F (134°C)	4
Double Wrapped Instrument Trays 16lbs each tray	3	Vacuum	273°F (134°C)	4
Textile Packs 12 lbs	4	Vacuum	273°F (134°C)	4
Unwrapped Nonporous Single Instrument	5	Gravity	273°F (134°C)	4
Fabric Packs maximum size: 12x12x20, 12 lbs	6	Gravity	253°F (122.8°C)	30
Vented Borosilicate glass containers, 500ml or smaller	7	Liquids	253°F (122.8°C)	30
Bowie-Dick Test	8	Test (VAC)	273°F (134°C)	3-1/2

1. Gravity cycles must be loaded in a manner to ensure no air is entrapped in the load. E.g., invert pans, beakers and similar items.



- 1 - Liquid Crystal Display (LCD)
- 2 - Light Emmitting Diode (LED)
- 3 - Cycle Buttons
- 4 - Heart Buttons

## GENERAL OPTIONS

**Validation Port, 2" inch V5**

Provides chamber penetration to accommodate various monitoring/control probes. One 2" is standard. Option V3.1 provides for additional 2" validation ports.

**Seismic Restraints V8**

Required in areas prone to seismic hazards. Secures sterilizer to building but allows for leveling. Designed to current California Code.

## UTILITY - RELATED OPTIONS

**Boost Pump for Low House Water Pressure P3**

Delivers required dynamic water pressure for efficient operation. Requires specified GPM flow. *Contact PRIMUS for details and performance specifications.*

**Transformers E1**

Reduces line voltage to required 110 VAC for operation of sterilizer controls.

E1A	220 vac to 110 vac
E1B	480 vac to 110 vac
E1C	480/240 to 240/120, 1 phase, 0.5 KVA

## UTILITY - RELATED OPTIONS (CON'T)

**Uninterruptible Power Supply E2**

In the event of electrical power loss and no emergency electrical power to sterilizer, this option provides electrical power to operate control system for up to 30 minutes, to complete the cycle.

## LOADING EQUIPMENT

Loading cart includes one bottom and one intermediate shelf with four adjustable levels. Additional shelves are available. Cart frames and shelves are 316L stainless steel welded, ground and polished. Shelf surfaces are stainless steel wire mesh. Transfer carriages include swivel casters with swivel locks and 5" wheels with wheel brakes. Loading cart and transfer carriages are recommended for chamber lengths 48 inches or longer. Pit Mounted units with chamber length equal or greater than 60" use one set of 2 floor carts

L4	Loading Cart
L5	Additional Cart Shelf
L6	Transfer Carriage
L7	Floor Cart
L8	Additional Floor Cart Shelves

*Contact PRIMUS for special loading equipment*

## FLOOR LOADER CART DIMENSIONS

CHAMBER SIZE	FLOOR CART QTY	A	B1	B2	C	D
J - 26"x 63"x 48"	1 - L7	24"	53.82"	60.19"	46"	16"
K - 26"x 63"x 76"	2 - L7	24"	53.82"	60.19"	36.5"	16"

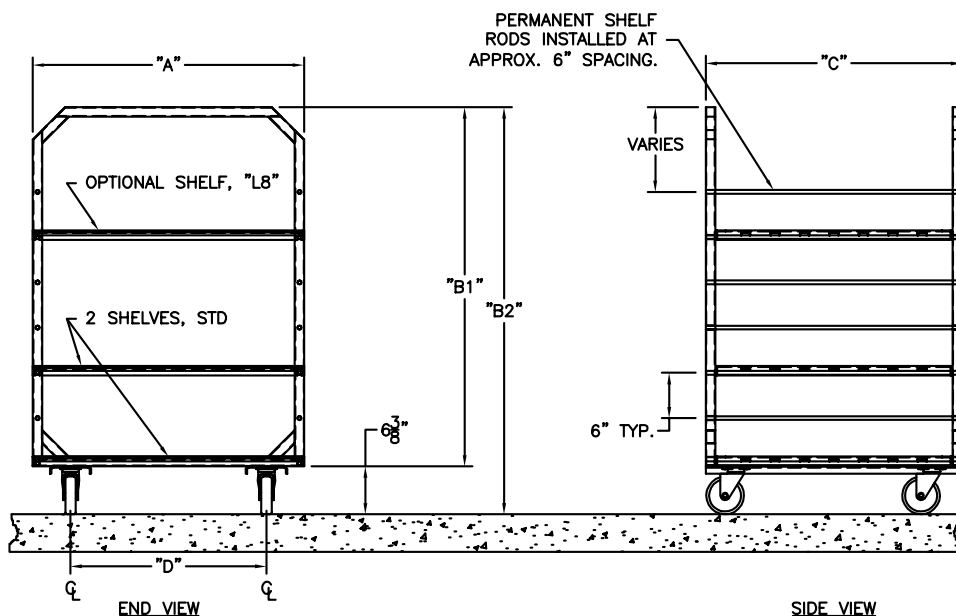

***“PRIMUS Sterilizer...  
...First In Quality Sterilization Products”***



Three 26" x 63" Pit-mounted Units

***QUALITY IS THE FOUNDATION OF PRIMUS STERILIZER CO., INC.  
EXEMPLIFIED THROUGH OUR CONTINUAL COMMITMENT  
TO DESIGN AND MANUFACTURE STERILIZERS  
TO THE HIGHEST INDUSTRY CERTIFICATIONS AND REGULATIONS,  
RETURNING SIGNIFICANT VALUE TO OUR CUSTOMERS BY  
CONSISTENTLY MEETING OR EXCEEDING EXPECTATIONS.***



**PRIMUS** Sterilizer Co., Inc. • 117 South 25<sup>th</sup> Street • Omaha, NE 68131

# PRIMUS Specification Data Worksheet

Complete the following by selecting or transferring those checked on preceding pages, required to meet your needs. Tear off and forward completed worksheet to PRIMUS Sales Department, fax 402-344-4251, or your local PRIMUS Representative. If you do not find an option or size listed to meet your requirement, please contact our Sales Department for additional information and assistance with a custom design to meet your specifications.

PRIMUS MODEL NUMBER		QUANTITY	
PROJECT NAME			
PROJECT ADDRESS			
COMPANY NAME		PHONE	
CONTACT NAME		FAX	
CONTACT EMAIL			
SPECIFICATION SECTION		ITEM NO.	
SHOWN ON DRAWING NO.		ROOM NO.	
PRIMUS QUOTE NO.			

GENERAL CONFIGURATIONS	
DA	Single Door
DB	Double Door
CD	Cabinet, 2 sides
CCL	Cabinet, 1 Side Left
CCR	Cabinet, 1 Side Right
CA	Recessed, 1 Wall
CB	Recessed, 2 Wall
NPN	Left Side Service (Std)
C30	Right Side Service Access & Control
C31	Control Panel opposite side of Service
PM	Pit Mounted (Std)
FM	Floor Mounted (Special Order with ramp or carriage/cart)
STEAM SOURCE	
EB1	Boiler, 208/3ph
EB2	Boiler, 240/3ph
EB3	Boiler, 480/3ph
EBO	Automatic boiler blow-down
LWC	Low Water Cutoff, Manual Reset
CLINICAL LABORATORY OPTIONS	
P9	Clean Steam to Chamber, SS Threaded Piping
P14	Low Temperature Flowing Steam
C24	Single Load Probe
CONTROLS & RELATED OPTIONS	
C6	PSS500 Control (Std)
C11	Serial Data Output
R7	Thermal Printer, 32 Column (Std)
R1	Impact Printer, Flush Mount 24 Column
R4	Thermal Printer, Take-up Reel
R4.1	Thermal Printer, Flush Mount 24 Column
R6	Impact Printer, 24 Column

GENERAL OPTIONS	
V5	Validation Port, 2.0" diameter
V8	Seismic Restraint
P25	Drain Line Strainer/Valve
EAC	Air Compressor
UTILITY - RELATED OPTIONS	
P3	Boost Pump for Low House Water
E1A	Transformer from 220V to 110V
E1B	Transformer from 480V to 110V
E1C	Transformer from 480/240 to 240/120V, 1 ph, 0.5KVA
E2	UPS maintains sterilizer operation for 30 minutes during power outage
E3	GFI Receptacle
LOADING EQUIPMENT	
L4	Loading Cart
L5	Additional Cart Shelves
L6	Transfer Carriage
L7	Floor Cart
L8	Additional Shelves
VESSEL OPTION	
C4	Jacket Pressure Display, Analog

Std = Standard Component  
 SS = Stainless Steel  
 N/A = Not Available

### YOUR LOCAL PRIMUS REPRESENTATIVE:

### FOR ADDITIONAL ASSISTANCE

To discuss your sterilization design needs or to request a Sterilizer Design Guide, please contact PRIMUS.



**PRIMUS**

Sterilizer Co., Inc. • 117 South 25<sup>th</sup> Street • Omaha, NE 68131

*Manufacturer reserves the right to modify materials or specification without notice.*