

# SPECIFICATION

# DATA SHEET

## PRIMUS CLINICAL – Small Size Sterilizers

These sterilizers are designed for Clinical applications including surgery, central sterile supply and clinical laboratories. PRIMUS sterilizers are designed and manufactured in the USA according to Quality Management Systems which are in compliance with ISO 9001:2000 and FDA's Good Manufacturing Practice (GMP) for Medical Devices: General Regulation (21CFR Part 820).



### STERILIZER DESIGN

The pressure vessel is the heart of any sterilizer. PRIMUS offers simple straight forward design. All PRIMUS pressure vessels are constructed of solid stainless steel and are fabricated by PRIMUS in our quality controlled, ASME facility. The interior chamber surface is polished to a mirror finish of <math><10\mu\text{in. Ra}</math>. The brilliant Pri-Mirror<sup>®</sup> reflective chamber finish sets the highest standard for cleanliness and offers easy spill clean-up and resistance to staining and degradation.

PRIMUS rectangular chambers eliminate the wasted space and high utility costs common to old-style cylindrical or elliptical chambers. (E.g. The PRIMUS 26 cu. ft. 26"x26"x67" sterilizer with vertical door, occupies less floor space and provides greater capacity than the conventional 24"x36"x48" hinged radial arm door sterilizers.)

PRIMUS' unique design reduces the high service cost associated with conventional hinged/radial arm doors and, most importantly, provides an added margin of operator safety.

PRIMUS vertically operating doors operate with minimal hand pressure. Where hands-free door operation is desired optional mushroom button actuated by elbow/forearm is offered. A foot operated kick-panel is offered for single door units only

The PRIMUS vertically sliding door design is efficient, reliable and inherently safe

### STERILIZER CYCLES

All PRIMUS Sterilizers include Gravity, Vacuum, and Liquid cycle settings. A Test/Vac cycle is provided for utilizing Bowie-Dick<sup>™</sup> tests.

For surgical packs, select one of the vacuum cycles. For the sterilization of liquids in open or vented containers, select a liquid cycle.

The time-tested and reliable PRIMUS PSS500 Microcomputer Control is an industrial microprocessor providing accuracy and automation for all customer requirements. This simple, versatile, control has become the first choice for both sterilizer users and service technicians.



PRIMUS Sterilizer Co., Inc. • 117 South 25<sup>th</sup> Street • Omaha, NE 68131

# PURCHASING SPECIFICATION DATA SHEET

## SPECIFICATION DATA SHEET

### GENERAL (Options italicized)

All models include Vacuum, Gravity and Liquids cycles. *A Low Temperature Flowing Steam option provides flowing steam at low temperatures for Research laboratories or specific applications.*

### VESSEL MATERIAL AND CONSTRUCTION

The sterilizer will have a double-wall design providing for a fully jacketed pressure vessel. The chamber cross section will be rectangular with width and height dimensions to include:

AA	16"x16"x26"	C	26"x26"x49"
A	20"x20"x38"	D	26"x26"x67"
B	26"x26"x39"		

The vessel material will be non-laminated solid stainless steel plate/sheet. The chamber, head-ring and door material will be 316L stainless steel with an interior Pri-Mirror® finish of <10µ in. Ra.

### DESIGN and MANUFACTURING APPROVALS

The vessel will be designed and constructed to ASME code Section VIII Division I and pressure rated for 45 PSIG and full vacuum. ASME Code Stamp and U-1 form shall bear the name of PRIMUS as the specified US manufacturer.

The sterilizer will be manufactured according to Quality Management Systems which are in compliance with ISO 9001:2000, will be UL listed and in conformance with CSA requirements.

### DOOR CONSTRUCTION

An inherently safe design, counterbalanced vertically operating door will be operable with minimal hand pressure and will operate within the overall dimensions of the sterilizer frame. In the open position, the insulated door shall be secured behind a panel preventing the operator from contact with hot surfaces. An interlock will prevent cycle start unless door is closed and locked.

### GENERAL CONSTRUCTION

The vessel will be insulated with 1" semi-rigid high temperature fiberglass board/blanket insulation overlaid with formed aluminum paneling and mounted in a structural steel frame. The frame will be enamel coated and fitted with adjustable legs on self-centering floor pads. The fascia and side panels will be 16-gauge, type 304 stainless-steel, removable for easy service access.

### Water Conservation

To conserve water and assure effluent exhausted to drain is 140°F or below, PRIMUS provides quench water on demand for exhaust effluent.

### EQUIPMENT WARRANTY

Sterilizer pressure vessels manufactured by PRIMUS are warranted against defects in workmanship and materials under normal use and operation for fifteen years where the sterilizer is continually maintained under PRIMUS service contract.

### SERVICE and EQUIPMENT ACCESS

Standard service access, when facing the unit, will be from left side and top. Wiring will be laid side-by-side and mechanically secured flat against the metal insulation cover. All wiring will be clearly labeled and readily visible for visual tracing. Piping components will be threaded rigid brass and flared copper fittings, positioned with sufficient space for removal and replacement without disassembly of the entire piping assembly. Wiring and piping components shall be nonproprietary, industrial grade, available through Authorized Service Agencies, local supply house, or direct from PRIMUS.

### STEAM SOURCE

Steam will be from an in-house steam source in the quantity and quality specified. *Optional electric steam boiler, clean steam boiler or steam-to-steam generator may be specified. Contact PRIMUS for additional information.*

### CONTROLS

A PSS500 microcomputer will offer a selection of eight (8) separate programs for the sterilization of wrapped goods, hard-goods, liquids and test cycles. Cycle parameters may be set by the user and are adaptable to a wide range of products. Alarms are annunciated, displayed and printed. Cycle process parameters will be displayed and recorded throughout the cycle. A side-mounted control panel and a thermal printer dot-matrix technology, with no moving parts in the print head, and 32 characters per line printing. A copy of the sterilization cycle will be available at the end of the run.



Standard Control Panel /Printer Arrangement



# PRIMUS Clinical - Small Sterilizers

## SINGLE DOOR

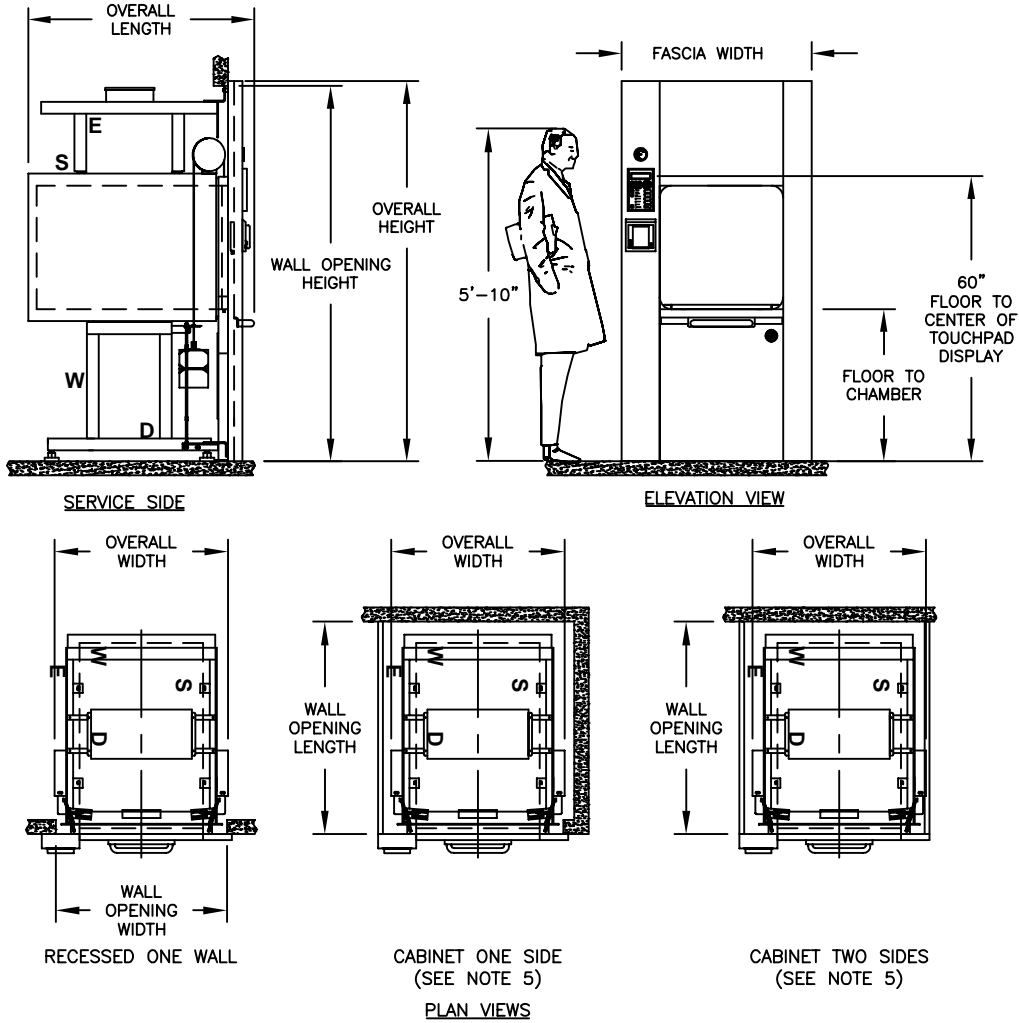

### VOLUME/DIMENSIONS CHART

\*Refer to General Arrangement (GA) drawings for details and final connection point to utility services (S-Steam, W-Water, D-Drain, E-Electrical).

MODEL	AA	A	B	C	D
<b>Chamber Size (w x h x l) inches/millimeters</b>	16 x 16 x 26 406.4 x 406.4 x 660.4	20 x 20 x 38 508 x 508 x 965.2	26 x 26 x 39 660.4 x 660.4 x 990.6	26 x 26 x 49 660.4 x 660.4 x 1244.6	26 x 26 x 67 660.4 x 660.4 x 1701.8
<b>Chamber Capacity</b>	3.9 ft <sup>3</sup> / .11 m <sup>3</sup>	8.8 ft <sup>3</sup> / .25 m <sup>3</sup>	15.3 ft <sup>3</sup> / .43 m <sup>3</sup>	19.2 ft <sup>3</sup> / .54 m <sup>3</sup>	26.2 ft <sup>3</sup> / .74 m <sup>3</sup>
Overall Width	25.00 / 635.0	28.75 / 730.25	35.50 / 901.7	35.50 / 901.7	35.50 / 901.7
Overall Height <sup>1</sup>	74.00 / 1879.6	74.00 / 1879.6	80.00 / 2032.0	80.00 / 2032.0	80.00 / 2032.0
Overall Length (SD) <sup>2,3</sup>	32.88 / 835.1	44.88 / 1139.8	47.56 / 1208.0	57.50 / 1460.5	75.50 / 1917.7
Wall Opening Width <sup>4</sup>	26.00 / 660.4	30.00 / 762.0	36.00 / 914.4	36.00 / 914.4	36.00 / 914.4
Wall Opening Height	73.00 / 1854.2	73.00 / 1854.2	79.00 / 2006.6	79.00 / 2006.6	79.00 / 2006.6
Wall Opening Length	32.00 / 812.8	44.00 / 1117.6	46.00 / 1168.4	54.00 / 1371.6	72.00 / 1828.8
Fascia Width	30.00 / 762.0	34.00 / 863.6	40.00 / 1016.0	40.00 / 1016.0	40.00 / 1016.0
Floor to Chamber	38.50 / 977.9	38.50 / 977.9	32.00 / 812.8	32.00 / 812.8	32.00 / 812.8

1. Fascia extends 1" beyond wall opening on each side overlapping the wall and sealing the opening.
2. Allow minimum 2" clearance at rear of recessed unit only. Cabinet side models have rear clearance built in.
3. Handle projects from the face of the fascia to the outer radius of the handle 2.375" for Models AA & A. Models B, C, & D the handle projects 4.25".
4. Contact PRIMUS for alternative wall opening.
5. Standard Left Side Service/equipment access shown. Optional right side access is available.



# PRIMUS Clinical - Small Sterilizers

## DOUBLE DOOR

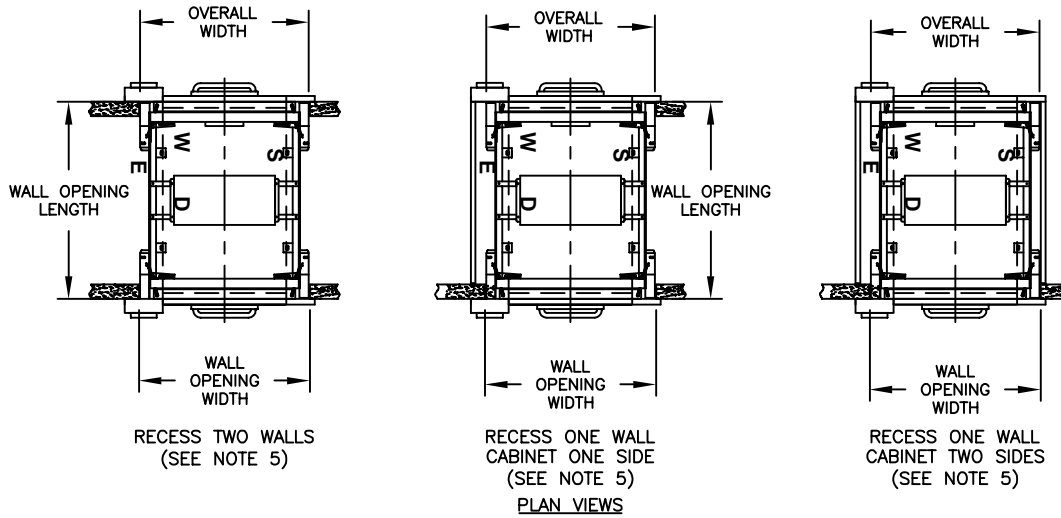
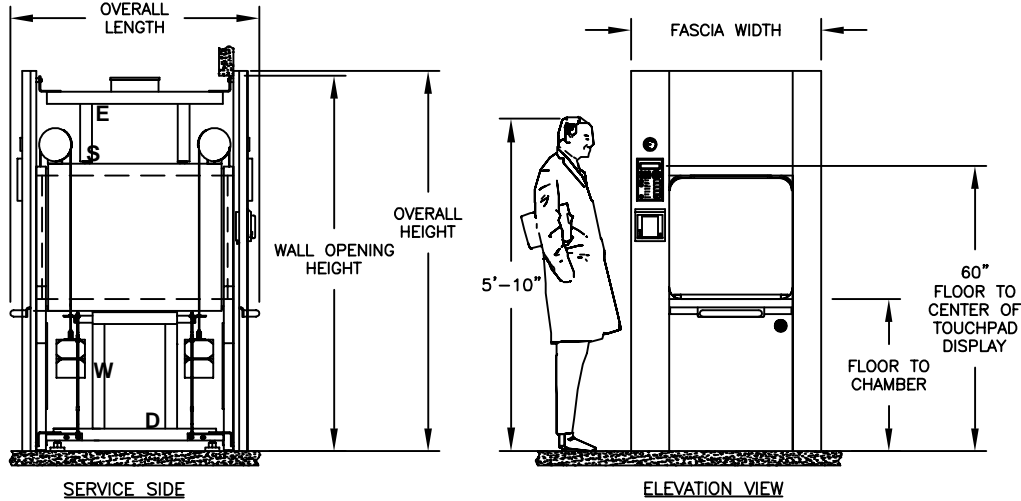

### VOLUME/DIMENSIONS CHART (CON'T)

\*Refer to General Arrangement (GA) drawings for details and final connection point to utility services  
(S-Steam, W-Water, D-Drain, E-Electrical).

MODEL	AA	A	B	C	D
<b>Chamber Size (w x h x l) inches/millimeters</b>	16 x 16 x 26 406.4 x 406.4 x 660.4	20 x 20 x 38 508 x 508 x 965.2	26 x 26 x 39 660.4 x 660.4 x 990.6	26 x 26 x 49 660.4 x 660.4 x 1244.6	26 x 26 x 67 660.4 x 660.4 x 1701.8
<b>Chamber Capacity</b>	3.9 ft <sup>3</sup> / .11 m <sup>3</sup>	8.8 ft <sup>3</sup> / .25 m <sup>3</sup>	15.3 ft <sup>3</sup> / .43 m <sup>3</sup>	19.2 ft <sup>3</sup> / .54 m <sup>3</sup>	26.2 ft <sup>3</sup> / .74 m <sup>3</sup>
Overall Width	25.00 / 635.0	28.75 / 730.25	35.50 / 901.7	35.50 / 901.7	35.50 / 901.7
Overall Height <sup>1</sup>	74.00 / 1879.6	74.00 / 1879.6	80.00 / 2032.0	80.00 / 2032.0	80.00 / 2032.0
Overall Length (DD) <sup>2,3</sup>	34.88 / 885.9	46.69 / 1185.9	52.44 / 1331.9	62.44 / 1585.98	80.44 / 2043.18
Wall Opening Width <sup>4</sup>	26.00 / 660.4	30.00 / 762.0	36.00 / 914.4	36.00 / 914.4	36.00 / 914.4
Wall Opening Height	73.00 / 1854.2	73.00 / 1854.2	79.00 / 2006.6	79.00 / 2006.6	79.00 / 2006.6
Wall Opening Length	27.69 / 703.3	40.44 / 1027.2	41.44 / 1052.6	51.44 / 1306.6	69.44 / 1763.8
Fascia Width	30.00 / 762.0	34.00 / 863.6	40.00 / 1016.0	40.00 / 1016.0	40.00 / 1016.0
Floor to Chamber	38.50 / 977.9	38.50 / 977.9	32.00 / 812.8	32.00 / 812.8	32.00 / 812.8

- Fascia extends 1" beyond wall opening on each side overlapping the wall and sealing the opening.
- Allow minimum 2" clearance at rear of recessed unit only. Cabinet side models have rear clearance built in.
- Handle projects from the face of the fascia to the outer radius of the handle 2.375" for Models AA & A. Models B, C, & D the handle projects 4.25".
- Contact PRIMUS for alternative wall opening.
- Standard Left Side Service/equipment access shown. Optional right side access is available.

## ARCHITECTURAL NOTES:

1. Allow sufficient space for traps, shut-off's, filters and other utility supply components.
2. Utility (service disconnects) shall be provided and installed "By Others".
3. Provide maximum mechanical and service access space, a minimum of 24", additional space required when boiler specified. See General Arrangement drawing, for placement of ancillary equipment and service access.
4. Some options affect utility services and overall dimensions.
5. The Manufacturer's Equipment Warranty does not cover failure due to improper utility provisions.
6. Drawings not to scale.
7. Wall thickness must be provided on double door models recessed through 1 wall, with cabinet sides.

## UTILITY SERVICES

Stub-in utility services within 6'-0" of final connection to sterilizer. Optimum sterilizer performance requires the specified utilities.

STEAM (S) Building Steam Supply . <b>Pipe Size:</b> 3/4" NPT . <b>Quality:</b> Condensate free 97% to 100% saturated vapor (suitably trapped to ensure dry steam and filtered to remove particulates) . <b>Pressure:</b> 50-80 PSIG Dynamic			WATER (W) Cold Water Supply . <b>Pipe Size:</b> 3/4" NPT . <b>Temperature:</b> < 70° F . <b>Pressure:</b> 50-70 PSIG Dynamic		DRAIN (D) Building Drain System Minimum 2"  . <b>Location:</b> Locate floor sink directly under sterilizer  <b>Note:</b> 1.) Exhaust discharge is cooled to < 140°F 2.) 12" x 12" x 8" floor sink is recommended by PRIMUS	ELECTRICAL (E) Building Power Supply  . <b>Volts:</b> 110 . <b>Phase:</b> Single . <b>Amps:</b> 10  <b>Note:</b> Provide <b>dedicated</b> circuit to sterilizer controls. If optional boiler is specified, do <b>not</b> share this service
MODEL	NPT	LBS/HR (KG/HR)	NPT	GPM (Liter)	NPT (Discharge Pipe Size)	
AA	3/4"	50.0 (22.68)	3/4"	8 (30)	3/4"	
A	3/4"	65.0 (29.48)	3/4"	8 (30)	3/4"	
B	3/4"	100.0 (45.36)	3/4"	8 (30)	3/4"	
C	3/4"	134.0 (60.78)	3/4"	14 (53)	1"	
D	3/4"	204.0 (92.53)	3/4"	14 (53)	1"	

## HVAC DATA Heat loss, at ambient of 70° F.

	MODEL	KBTU'S/HR
<b>SINGLE DOOR:</b> Through one wall, at fascia	AA	1.5
	A	2.2
	B	4.1
	C	4.1
	D	4.1
<b>SINGLE DOOR:</b> Through one wall, service area	AA	1.9
	A	3.4
	B	5.7
	C	7.1
	D	9.7
<b>SINGLE DOOR:</b> Free standing, cabinet total	AA	3.4
	A	5.6
	B	9.8
	C	11.2
	D	13.8

	MODEL	KBTU'S/HR
<b>DOUBLE DOOR:</b> Through one wall, at fascia	AA	1.5
	A	2.2
	B	4.1
	C	4.1
	D	4.1
<b>DOUBLE DOOR:</b> Through one wall, service area	AA	3.3
	A	5.1
	B	7.8
	C	9.7
	D	11.5
<b>DOUBLE DOOR:</b> Through two walls, at each fascia	AA	1.5
	A	2.2
	B	4.1
	C	4.1
	D	4.1
<b>DOUBLE DOOR:</b> Through two walls, service area	AA	1.8
	A	2.9
	B	3.7
	C	5.6
	D	7.4

Use the following pages to custom design your sterilizer by checking the boxes of the configuration and options required for your project. Transfer all items checked to the Specification Worksheet (Page 12) and fax to PRIMUS Sales Department or to your local Sales Representative for a quotation. If you do not find an option or size listed to meet your requirements, please contact our Project Manager for additional information and assistance with a custom design to meet your specifications.

**Model Number Notation**

DD = Double Door  
↓

PSS5-\_\_-M\_\_-\_\_

↑            ↑

AA    S = House Steam  
A     E = Electric Boiler  
B  
C  
D

**Five models are offered:**  
 AA - 16" x 16" x 26"  
 A - 20" x 20" x 38"  
 B - 26" x 26" x 39"  
 C - 26" x 26" x 49"  
 D - 26" x 26" x 67"

*A detailed formatted specification, suitable for inclusion in formal contract documents, is available on request.*

**Note:** Use the above format to determine PRIMUS Model number and insert below and on Page 12, Specification Worksheet.

PRIMUS Clinical Steam Pressure Sterilizer, Model Number PSS5\_\_\_\_\_.

**SELECT CONFIGURATION**

**Door**

- DA - Single Door
- DB - Double Door

**Recessed**

- CA - One Wall
- CB - Two Walls

**Steam Source**

- House Supply
- Electric Boiler<sup>1,2</sup>
  - EB1 - 208/3 phase
  - EB2 - 240/3 phase
  - EB3 - 480/3 phase
  - Other \_\_\_\_\_
- EB0<sup>4</sup>- Auto. Blowdown
- LWC<sup>3</sup>- Low Water Cutoff with Manual Reset

**Cabinet**

- CD - Panels Both Sides
- CCL - Left Side Panel
- CCR - Right Side Panel
- CE - Top Panel

**Service and Equipment Access**

- Left Side (Standard)
- Right Side

1. Electric boilers are available in Carbon Steel or Stainless Steel Electric. Carbon Steel Boilers are integral on AA, A, B sizes. Additional options, if selected, may require stand-alone on these sizes. Specify whenever stand-alone is required on any model.
2. Contact PRIMUS for overall dimensions and utility connections.
3. Required in CA, IA, MA, MD, NC, TX and WA
4. If Option LWC is required, "the automatic" feature is disabled. The boiler will need to be manually reset.

## CLINICAL LABORATORY CONFIGURATIONS

**Low Temperature Flowing Steam P14**  
For media preparation, formula and similar uses. Pasteurization is accomplished with flowing steam. In addition to standard sterilizer temperature ranges, this option allows cycles to operate in the range of 168°F (76°C) to 220°F (104°C). Not intended for reprocessing reusable medical devices.

**Control Cycle on Load Temperature C24**  
Used to establish the most beneficial cycle temperature and exhaust rate parameters. Monitors load temperature and controls the start of sterilization. Which will establish optimal parameters for liquid loads and for loads with complex load geometries and a difficult path for steam penetration.

### CONTROLS AND RELATED OPTIONS (Contact PRIMUS for details and performance specifications)

**PSS500 Control C6**  
PSS500 microcomputer with eight (8) cycles; seven (7) programmable and 1 preset Test cycle are standard. A vertical touchpad contains a Liquid Crystal Display (LCD) mounted on a side-mounted control panel with a thermal printer. Cycle progression is displayed by Light Emitting Diodes (LEDs) on the operator panel and printed, 32 characters per line printing. A second copy of the entire sterilization cycle printable at the end of the run.

**Impact Printer R1**  
Replaces standard 32 column thermal head printer with a 24 column impact printer.

**Serial Data Output C11**  
Supervisory use to capture electronic record of each sterilization cycle. Cycle hard copy and display data is transmitted via RS232 in real time to a remote computer, up to 100 feet away, for display and recording. Hard copy records may be printed from the computer.

Cycles may be programmed by the end user but any deviation from the factory preset values must be validated by the end-user.

FACTORY PRESET CYCLES				
Load Type	Cycle Number	Cycle Type	Sterilize Temp	Sterilize Time (min)
Double Wrapped Instruments 16 lbs each tray	1	Vacuum	273°F (134°C)	15
Unwrapped Nonporous Single Instrument	2	Vacuum	273°F (134°C)	4
Double Wrapped Instrument Trays 16 lbs each tray	3	Vacuum	273°F (134°C)	4
Textile Pack 12 lbs	4	Vacuum	273°F (134°C)	4
Unwrapped Nonporous Single Instrument	5	Gravity	273°F (134°C)	4
Fabric Packs maximum size: 12x12x20, 12 lbs	6	Gravity <sup>1</sup>	253°F (122.8°C)	30
Vented Borosilicate glass containers, 500 ml or smaller	7	Liquids	253°F (122.8°C)	30
Bowie-Dick Test	8	Test (VAC)	273°F (134°C)	3-1/2

1. Gravity cycles must be loaded in a manner to ensure no air is entrapped in the load. E.g., invert pans, beakers and similar items.



- 1 - Liquid Crystal Display (LCD)
- 2 - Light Emmitting Diode (LED)
- 3 - Cycle Buttons
- 4 - Heart Buttons

## GENERAL OPTIONS

- Validation Port, 1 inch V3.1**  
Provides chamber penetration to accommodate various monitoring/control probes. Standard on B, C, and D models, optional for Models AA and A.
  
- Seismic Restraints V8**  
Required in areas prone to seismic hazards. Secures sterilizer to building but allows for leveling. Designed to current California Code.
  
- Power Operated Door DF**  
On small size models, replaces standard manual fingertip door operation with hydraulic power operation actuated by mushroom-button switch mounted adjacent to chamber. Double Door Models include control panel pad actuation in lieu of mushroom button.

## UTILITY - RELATED OPTIONS

- Boost Pump for Low House Water Pressure P3**  
Delivers required dynamic water pressure for efficient operation. Requires specified GPM flow. *Contact PRIMUS for details and performance specifications.*
  
- Transformers E1**  
Reduces line voltage to required 110 VAC for operation of sterilizer controls.

	E1A	220 vac to 110 vac
	E1B	480 vac to 110 vac
	E1C	480/240 to 240/120, 1 phase, 0.5 KVA

- Uninterruptible Power Supply E2**  
In the event of electrical power loss and no emergency electrical power to sterilizer, this option provides electrical power to operate control system for up to 30 minutes, to complete the cycle.

## LOADING EQUIPMENT

Standard chamber shelving includes a fixed, removable, wire mesh bottom shelf. As an option an extendable bottom shelf, is available. Optional additional chamber shelf(ves) may be specified.

Loading cart includes one bottom and one intermediate shelf with four adjustable levels. Additional shelves are available. Cart frames and shelves are 316L stainless steel welded, ground and polished. Shelf surfaces are stainless steel wire mesh. Transfer carriages include swivel casters with swivel locks and 5” wheels with wheel brakes. Loading cart and transfer carriages are recommended for chamber lengths greater than 48 inches.

	L1	Removable Bottom Shelf
	L2	Extendable Bottom Shelf
	L3	Additional Chamber Shelf
	L4	Loading Cart (n/a 16"x16"x26" Model)
	L5	Additional Cart Shelf
	L6	Transfer Carriage

*Contact PRIMUS for special loading equipment requirements.*



# PRIMUS Clinical - Small Sterilizers

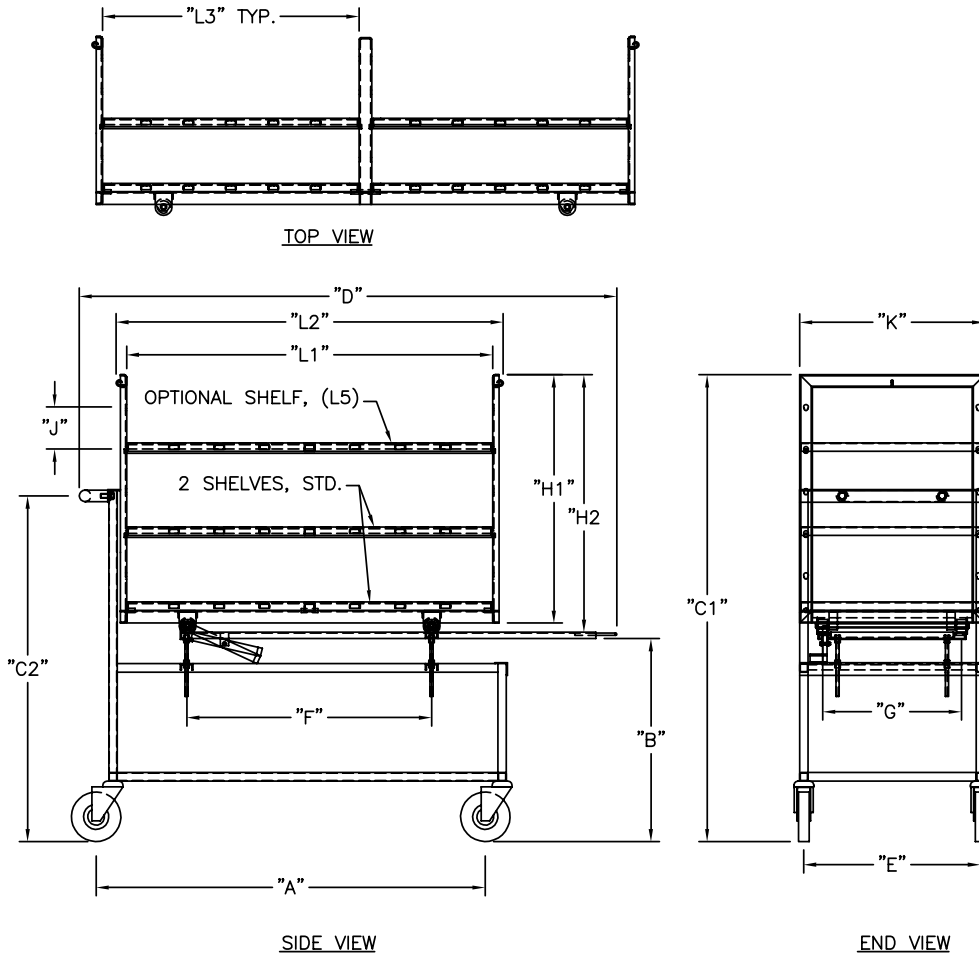

**Transfer Carriage and Loading Cart Dimensions<sup>1</sup>**

CHAMBER SIZE	CARRIAGE QTY	CART QTY	A	B	C1	C2	D	E	F
AA-16"x16"x26"	N/A	N/A							
A - 20"x20"x38"	1-L6	1-L4	38"	38.50"	55.81"	48.06"	51.56"	19"	34.50"
B - 26"x26"x39"	1-L6	1-L4	39.25"	32"	53.63"	41.06"	53.50"	21"	35.50"
C - 26"x26"x49"	1-L6	1-L4	49.25"	32"	53.63"	41.06"	63.50"	21"	45.50"
D - 26"x26"x67"	1-L6	1-L4	67.25"	32"	53.63"	41.06"	80.75"	21"	48"

**Transfer Carriage and Loading Cart Dimensions Cont'd**

CHAMBER SIZE	CARRIAGE QTY	CART QTY	G	H1	H2	J <sup>2</sup>	K	L1	L2	L3
AA-16"x16"x26"	N/A	N/A								
A - 20"x20"x38"	1-L6	1-L4	13.50"	15"	16.38"	3"	18"	33"	36"	N/A
B - 26"x26"x39"	1-L6	1-L4	16.50"	19.50"	20.88"	4"	24"	34"	37"	N/A
C - 26"x26"x49"	1-L6	1-L4	16.50"	19.50"	20.88"	4"	24"	44"	47"	N/A
D - 26"x26"x67"	1-L6	1-L4	16.50"	19.50"	20.88"	4"	24"	62.50"	65"	30.50"

1. Typical Transfer Carriage and Loading Cart depicted. Contact PRIMUS for special design to accommodate your load requirements or existing equipment.  
 2. Standard shelf spacing, contact PRIMUS for special shelf placement.

## ELECTRIC BOILERS

MODEL		AA	A	B	C	D
Chamber Size (w x h x l) inches/millimeters		16 x 16 x 26 406.4 x 406.4 x 660.4	20 x 20 x 38 508 x 508 x 965.2	26 x 26 x 39 660.4 x 660.4 x 990.6	26 x 26 x 49 660.4 x 660.4 x 1244.6	26 x 26 x 67 660.4 x 660.4 x 1701.8
Boiler Size	KW/Hr.	24.0	24.0	36.0	48.0	72.0
Boiler Steam Output	lbs./Hr	73.0	73.0	108.0	145.0	217.0
Integral	Model	EB1-AA	EB1-A	N/A	N/A	N/A
Stand Alone	Model	EB-AA	EB-A	EB-B	EB-C	EB-D
V.A.C. 208, 3 Ph	Amperes	67	67	100	134	200
V.A.C.240, 3 Ph	Amperes	58	58	87	116	174
V.A.C. 480, 3 Ph	Amperes	29	29	44	58	87
V.A.C. 110, 60 hz <sup>1</sup>	Amperes	10	10	10	10	10

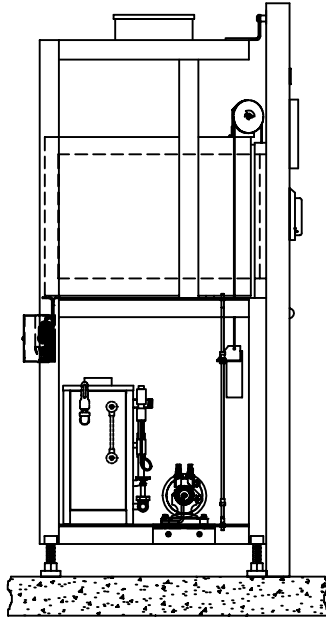

SIDE VIEW

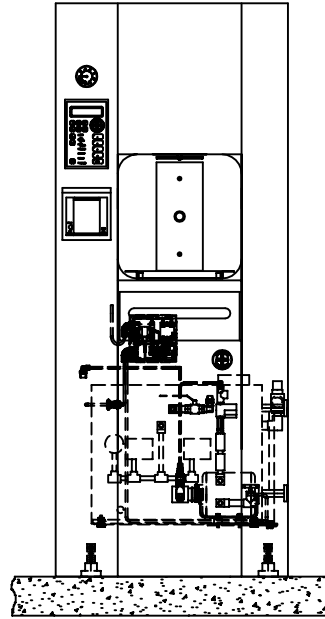

FRONT VIEW

16" x 16" x 26" shown with integral boiler

## Sterilizer Dimensions, Cubage & Weights

Model Sterilizer Size inches/millimeters	AA 16" x 16" x 26" 406.4 x 406.4 x 660.4	A 20" x 20" x 38" 508 x 508 x 965.2	B 26" x 26" x 39" 660.4 x 660.4 x 990.6	C 26" x 26" x 49" 660.4 x 660.4 x 1244.6	D 26" x 26" x 67" 660.4 x 660.4 x 1701.8
Overall Dimensions, of Frame	25 x 73 x 32-1/2 635 x 1854.2 x 825.5	28-3/4 x 73 x 45 730.25 x 1854.2 x 1143	35-1/2 x 79 x 50 901.7 x 2006.6 x 1270	35-1/2 x 79 x 60 901.7 x 2006.6 x 1524	35-1/2 x 79 x 78 901.7 x 2006.6 x 1981.2
Weight, Single Door	<b>CONTACT PRIMUS FOR WEIGHTS</b>				
Weight, Double Door					
Crated Weight (Additional)	200 lbs/ 91kg	200 lbs/ 91kg	200 lb/ 91kg	200 lbs/ 91kg	200 lbs/ 91kg
Crated Dimensions	43 x 81 x 47 1092.2 x 2057.4 x 1193.8	47 x 81 x 59 1193.8 x 2057.4 x 1498.6	61 x 84 x 61 1549.4 x 2133.6 x 1549.4	61 x 84 x 71 1549.4 x 2133.6 x 1803.4	61 x 84 x 89 1549.4 x 2133.6 x 2260.6
Crated Cube	95 cu ft/ 3m <sup>3</sup>	130 cu ft/ 4 m <sup>3</sup>	181 cu ft/ 5 m <sup>3</sup>	211 cu ft/ 6 m <sup>3</sup>	264 cu ft/ 8 m <sup>3</sup>
Loading Equipment	N/A	121 lbs/ 55 kg	153 lbs/ 69 kg	175 lbs/ 79 kg	246 lbs/ 112 kg
Boiler	175 lbs/ 79 kg	200 lbs/ 91 kg	250 lbs/ 113 kg	375 lbs/ 170 kg	450 lbs/ 204 kg

**“PRIMUS Sterilizer...  
...First In Quality Sterilization Products”**



**The VERSATILE 26”x 26” x 39”  
Double the chamber capacity...  
Triple the throughput...  
And occupy only 1-1/2 square feet  
more of floor space**

**POPULAR 20”x 20” x 38”  
One full-size closed instrument tray\* per shelf**

**HIGH CAPACITY 26”x26”x39”  
Holds 3 full-size closed instrument trays\* per shelf  
\*SteriTite® Sealed Containers provided by Case Medical, Inc.**

**QUALITY IS THE FOUNDATION OF PRIMUS STERILIZER CO., INC.  
EXEMPLIFIED THROUGH OUR CONTINUAL COMMITMENT  
TO DESIGN AND MANUFACTURE STERILIZERS  
TO THE HIGHEST INDUSTRY CERTIFICATIONS AND REGULATIONS,  
RETURNING SIGNIFICANT VALUE TO OUR CUSTOMERS BY  
CONSISTENTLY MEETING OR EXCEEDING EXPECTATIONS.**

*This document and data contained within is intended for the exclusive use of PRIMUS customers, including architects or designers. It shall not be reproduced in whole or in part without permission of PRIMUS Sterilizer Co., Inc. Any authorized reproduction must bear the entire page to include Headers and Footers.*



**PRIMUS** Sterilizer Co., Inc. • 117 South 25<sup>th</sup> Street • Omaha, NE 68131

## PRIMUS Specification Data Worksheet

Complete the following by selecting or transferring the options, checked on preceding pages, required to meet your needs. Tear off and forward completed worksheet to PRIMUS Sales Department, fax 402-344-4251, or your local PRIMUS Representative. If you do not find an option or size listed to meet your requirement, please contact our Sales Department for additional information and assistance with a custom design to meet your specifications.

PRIMUS MODEL NUMBER		QUANTITY	
PROJECT NAME			
PROJECT ADDRESS			
COMPANY NAME		PHONE	
CONTACT NAME		FAX	
CONTACT EMAIL			
SPECIFICATION SECTION		ITEM NO.	
SHOWN ON DRAWING NO.		ROOM NO.	
PRIMUS QUOTE NO.			

GENERAL CONFIGURATIONS	
DA	Single Door
DB	Double Door
DG	Foot Operated Auto Door (Single Door)
DE	Door(s) Manually Operated (Std)
CD	Cabinet, 2 sides
CCL	Cabinet, 1 Side Left
CCR	Cabinet, 1 Side Right
CA	Recessed, 1 Wall
CB	Recessed, 2 Wall
NPN	Left Side Service (Std)
C30	Right Side Service Access & Control
C3	Control Panel opposite side of Service
CE	Top Panel
CF	Rear Panel

STEAM SOURCE	
EB1	Boiler, 208/3ph
EB2	Boiler, 240/3ph
EB3	Boiler, 480/3ph
EBO	Automatic boiler blow-down
LWC	Low Water Cutoff, Manual Reset

CLINICAL LABORATORY OPTIONS	
P9	Clean Steam to Chamber, SS Threaded Piping
P14	Low Temperature Flowing Steam
C24	Single Load Probe

CONTROLS & RELATED OPTIONS	
C6	PSS500 Control (Std)
C11	Serial Data Output
R1	Impact Printer, Flush Mount 24 Column
R7	Thermal Printer, 32 Column (Std)
R4	Thermal Printer, Take-up Reel
R4.1	Thermal Printer, Flush Mount 24 Column
R6	Impact Printer, 24 Column

### FOR ADDITIONAL ASSISTANCE

To discuss your sterilization design needs or to request a Sterilizer Design Guide, please contact PRIMUS.

GENERAL OPTIONS	
V3.1	Validation Port, 1.0" diameter
V8	Seismic Restraint
P25	Drain Line Strainer/Valve
DF	Power Operated Door (Single Door Only)
EAC	Air Compressor

UTILITY - RELATED OPTIONS	
P3	Boost Pump for Low House Water
E1A	Stepping Transformer from 220V to 110V
E1B	Stepping Transformer from 480V to 110V
E1C	Stepping Transformer from 480/240 to 240/120V, 1 ph, 0.5KVA
E2	UPS maintains sterilizer operation for 30 minutes during power outage
E3	GFI Receptacle

LOADING EQUIPMENT	
L1	Removable Bottom Shelf (Std)
L2	Extendable Bottom Shelf
L3	Additional Chamber Shelves
L4	Loading Cart (N/A on 16"x16"x26")
L5	Additional Cart Shelves (N/A on 16"x16"x26")
L6	Transfer Carriage

VESSEL OPTION	
C4	Jacket Pressure Display, Analog

Std = Standard Component  
 SS = Stainless Steel  
 N/A = Not Available

### YOUR LOCAL PRIMUS REPRESENTATIVE:



**PRIMUS**

Sterilizer Co., Inc. • 117 South 25<sup>th</sup> Street • Omaha, NE 68131

*Manufacturer reserves the right to modify materials or specification without notice.*